

**SUN2000-(175KTL-H0, 185KTL-INH0, 185KTL-H1)**

# **User Manual**

**Issue**                    11  
**Date**                     2021-05-21



**Copyright © Huawei Technologies Co., Ltd. 2021. All rights reserved.**

No part of this document may be reproduced or transmitted in any form or by any means without prior written consent of Huawei Technologies Co., Ltd.

## **Trademarks and Permissions**



HUAWEI and other Huawei trademarks are trademarks of Huawei Technologies Co., Ltd.

All other trademarks and trade names mentioned in this document are the property of their respective holders.

## **Notice**

The purchased products, services and features are stipulated by the contract made between Huawei and the customer. All or part of the products, services and features described in this document may not be within the purchase scope or the usage scope. Unless otherwise specified in the contract, all statements, information, and recommendations in this document are provided "AS IS" without warranties, guarantees or representations of any kind, either express or implied.

The information in this document is subject to change without notice. Every effort has been made in the preparation of this document to ensure accuracy of the contents, but all statements, information, and recommendations in this document do not constitute a warranty of any kind, express or implied.

## **Huawei Technologies Co., Ltd.**

Address: Huawei Industrial Base  
Bantian, Longgang  
Shenzhen 518129  
People's Republic of China

Website: <https://e.huawei.com>

# About This Document

## Overview





This document describes the SUN2000-175KTL-H0, SUN2000-185KTL-INH0, and SUN2000-185KTL-H1 (SUN2000 for short) in terms of their installation, electrical connections, commissioning, maintenance, and troubleshooting. Before installing and operating the inverter, ensure that you are familiar with the features, functions, and safety precautions provided in this document.

## Intended Audience

This document is intended for photovoltaic (PV) plant operating personnel and qualified electricians.

## Symbol Conventions

The symbols that may be found in this document are defined as follows.

Symbol	Description
	Indicates a hazard with a high level of risk which, if not avoided, will result in death or serious injury.
	Indicates a hazard with a medium level of risk which, if not avoided, could result in death or serious injury.
	Indicates a hazard with a low level of risk which, if not avoided, could result in minor or moderate injury.
	Indicates a potentially hazardous situation which, if not avoided, could result in equipment damage, data loss, performance deterioration, or unanticipated results.  NOTICE is used to address practices not related to personal injury.

Symbol	Description
 NOTE	Supplements the important information in the main text. NOTE is used to address information not related to personal injury, equipment damage, and environment deterioration.

## Change History

Changes between document issues are cumulative. The latest document issue contains all updates made in previous issues.

### Issue 11 (2021-05-21)

Updated [5.7 Installing the DC Input Power Cable](#).

### Issue 10 (2021-04-26)

Updated [5.7 Installing the DC Input Power Cable](#).

Updated [A Securing Y-Branch Connectors](#).

### Issue 09 (2021-03-15)

Updated [4.2 Preparing Tools](#).

Updated [5.7 Installing the DC Input Power Cable](#).

Updated [8.5 Troubleshooting](#).

### Issue 08 (2021-01-22)

Updated [4.3.1 Environment Requirements](#).

Updated [D Grid Code](#).

### Issue 07 (2020-12-21)

Updated [5.6 Connecting the AC Output Power Cable](#).

### Issue 06 (2020-11-30)

Updated [4.5 Installing the Inverter](#).

Updated [6.2 System Power-On](#).

### Issue 05 (2020-08-30)

Updated [2.1 Product Overview](#).

Updated [4.3.1 Environment Requirements](#).

Updated [4.5 Installing the Inverter](#).

Updated [6.2 System Power-On](#).

Updated [7.1 Operations with the App](#).

Updated [8.3 Routine Maintenance](#).

#### **Issue 04 (2020-03-03)**

Updated [1 Safety Information](#).

Updated [2.3.1 Label Description](#).

Updated [5.8 Installing the Communications Cable](#).

Updated [7.1 Operations with the App](#).

Updated [10 Technical Data](#).

Added [A Securing Y-Branch Connectors](#).

Added [C Domain Name List of Management Systems](#).

#### **Issue 03 (2019-09-10)**

Updated [5.7 Installing the DC Input Power Cable](#).

Updated [8.5 Troubleshooting](#).

Added [B String Access Detection](#).

#### **Issue 02 (2019-06-05)**

Updated [2.2 Appearance](#).

#### **Issue 01 (2019-05-15)**

This issue is used for first office application (FOA).

---

# Contents

---

<b>About This Document.....</b>	<b>ii</b>
<b>1 Safety Information.....</b>	<b>1</b>
1.1 General Safety.....	1
1.2 Personnel Requirements.....	2
1.3 Electrical Safety.....	3
1.4 Installation Environment Requirements.....	4
1.5 Mechanical Safety.....	4
1.6 Commissioning.....	5
1.7 Maintenance and Replacement.....	6
<b>2 Overview.....</b>	<b>7</b>
2.1 Product Overview.....	7
2.2 Appearance.....	9
2.3 Label Description.....	12
2.3.1 Label Description.....	12
2.3.2 Product Nameplate.....	13
2.4 Working Principles.....	14
2.4.1 Circuit Diagram.....	14
2.4.2 Working Modes.....	15
<b>3 Solar Inverter Storage.....</b>	<b>17</b>
<b>4 Installation.....</b>	<b>19</b>
4.1 Checking Before Installation.....	19
4.2 Preparing Tools.....	19
4.3 Determining the Installation Position.....	21
4.3.1 Environment Requirements.....	21
4.3.2 Space Requirements.....	22
4.4 Installing the Mounting Bracket.....	24
4.4.1 Support-mounted Installation.....	25
4.4.2 Wall-mounted Installation.....	26
4.5 Installing the Inverter.....	27
<b>5 Electrical Connections.....</b>	<b>30</b>
5.1 Precautions.....	30

5.2 Crimping an OT or DT Terminal.....	30
5.3 Opening the Maintenance Compartment Door.....	33
5.4 (Optional) Replacing the Crimping Module.....	35
5.5 (Optional) Installing the Power Cable of the Tracking System.....	35
5.6 Connecting the AC Output Power Cable.....	36
5.7 Installing the DC Input Power Cable.....	40
5.8 Installing the Communications Cable.....	46
5.9 Closing the Maintenance Compartment Door.....	49
<b>6 System Commissioning.....</b>	<b>51</b>
6.1 Check Before Power-on.....	51
6.2 System Power-On.....	51
<b>7 Man-Machine Interactions.....</b>	<b>53</b>
7.1 Operations with the App.....	53
7.1.1 App Introduction.....	53
7.1.2 Downloading and Installing the App.....	54
7.1.3 Logging In to the App.....	55
7.1.4 Operations Related to the Advanced User.....	59
7.1.4.1 Setting Grid Parameters.....	60
7.1.4.2 Setting Protection Parameters.....	60
7.1.4.3 Setting Feature Parameters.....	61
7.1.5 Operations Related to the Special User.....	65
7.1.5.1 Setting Grid Parameters.....	65
7.1.5.2 Setting Protection Parameters.....	68
7.1.5.3 Setting Feature Parameters.....	69
7.1.5.4 Setting Power Adjustment Parameters.....	74
7.2 Operations with a USB Flash Drive.....	77
7.2.1 Exporting Configurations.....	77
7.2.2 Importing Configurations.....	79
7.2.3 Exporting Data.....	80
7.2.4 Upgrading.....	81
<b>8 Maintenance.....</b>	<b>83</b>
8.1 System Power-Off.....	83
8.2 Power-Off for Troubleshooting.....	83
8.3 Routine Maintenance.....	85
8.4 Replacing a Fan.....	87
8.5 Troubleshooting.....	90
<b>9 Handling the Inverter.....</b>	<b>101</b>
9.1 Removing the SUN2000.....	101
9.2 Packing the SUN2000.....	101
9.3 Disposing of the SUN2000.....	101
<b>10 Technical Data.....</b>	<b>102</b>

---

<b>A Securing Y-Branch Connectors.....</b>	<b>106</b>
<b>B String Access Detection.....</b>	<b>109</b>
<b>C Domain Name List of Management Systems.....</b>	<b>112</b>
<b>D Grid Code.....</b>	<b>113</b>
<b>E Acronyms and Abbreviations.....</b>	<b>118</b>

# 1 Safety Information

---

## 1.1 General Safety

### Statement

Before installing, operating, and maintaining the equipment, read this document and observe all the safety instructions on the equipment and in this document.

The "NOTICE", "CAUTION", "WARNING", and "DANGER" statements in this document do not cover all the safety instructions. They are only supplements to the safety instructions. Huawei will not be liable for any consequence caused by the violation of general safety requirements or design, production, and usage safety standards.

Ensure that the equipment is used in environments that meet its design specifications. Otherwise, the equipment may become faulty, and the resulting equipment malfunction, component damage, personal injuries, or property damage are not covered under the warranty.

Follow local laws and regulations when installing, operating, or maintaining the equipment. The safety instructions in this document are only supplements to local laws and regulations.

Huawei will not be liable for any consequences of the following circumstances:

- Operation beyond the conditions specified in this document
- Installation or use in environments which are not specified in relevant international or national standards
- Unauthorized modifications to the product or software code or removal of the product
- Failure to follow the operation instructions and safety precautions on the product and in this document
- Equipment damage due to force majeure, such as earthquakes, fire, and storms
- Damage caused during transportation by the customer
- Storage conditions that do not meet the requirements specified in this document

## General Requirements

---

 **DANGER**

Do not work with power on during installation.

---

- Do not install, use, or operate outdoor equipment and cables (including but not limited to moving equipment, operating equipment and cables, inserting connectors to or removing connectors from signal ports connected to outdoor facilities, working at heights, and performing outdoor installation) in harsh weather conditions such as lightning, rain, snow, and level 6 or stronger wind.
- After installing the equipment, remove idle packing materials such as cartons, foam, plastics, and cable ties from the equipment area.
- In the case of a fire, immediately leave the building or the equipment area, and turn on the fire alarm bell or make an emergency call. Do not enter the building on fire in any case.
- Do not scrawl, damage, or block any warning label on the equipment.
- Tighten the screws to the specified torque using tools when installing the equipment.
- Understand the components and functioning of a grid-tied PV power system and relevant local standards.
- Repaint any paint scratches caused during equipment transportation or installation in a timely manner. Equipment with scratches cannot be exposed to an outdoor environment for a long period of time.
- Do not open the host panel of the equipment.

## Personal Safety

- If there is a probability of personal injury or equipment damage during operations on the equipment, immediately stop the operations, report the case to the supervisor, and take feasible protective measures.
- Use tools correctly to avoid hurting people or damaging the equipment.
- Do not touch the energized equipment, as the enclosure is hot.

## 1.2 Personnel Requirements

- Personnel who plan to install or maintain Huawei equipment must receive thorough training, understand all necessary safety precautions, and be able to correctly perform all operations.
- Only qualified professionals or trained personnel are allowed to install, operate, and maintain the equipment.
- Only qualified professionals are allowed to remove safety facilities and inspect the equipment.
- Personnel who will operate the equipment, including operators, trained personnel, and professionals, should possess the local national required qualifications in special operations such as high-voltage operations, working at heights, and operations of special equipment.

- Only professionals or authorized personnel are allowed to replace the equipment or components (including software).

 **NOTE**

- Professionals: personnel who are trained or experienced in equipment operations and are clear of the sources and degree of various potential hazards in equipment installation, operation, and maintenance
- Trained personnel: personnel who are technically trained, have required experience, are aware of possible hazards on themselves in certain operations, and are able to take protective measures to minimize the hazards on themselves and other people
- Operators: operation personnel who may come in contact with the equipment, except trained personnel and professionals

## 1.3 Electrical Safety

### Grounding

- For the equipment that needs to be grounded, install the ground cable first when installing the equipment and remove the ground cable last when removing the equipment.
- Do not damage the ground conductor.
- Do not operate the equipment in the absence of a properly installed ground conductor.
- Ensure that the equipment is connected permanently to the protective ground. Before operating the equipment, check its electrical connection to ensure that it is securely grounded.

### General Requirements

---

 **DANGER**

Before connecting cables, ensure that the equipment is intact. Otherwise, electric shocks or fire may occur.

---

- Ensure that all electrical connections comply with local electrical standards.
- Obtain approval from the local electric utility company before using the equipment in grid-tied mode.
- Ensure that the cables you prepared meet local regulations.
- Use dedicated insulated tools when performing high-voltage operations.

### AC and DC Power

---

 **DANGER**

Do not connect or disconnect power cables with power on. Transient contact between the core of the power cable and the conductor will generate electric arcs or sparks, which may cause fire or personal injury.

---

- Before making electrical connections, switch off the disconnecter on the upstream device to cut off the power supply if people may contact energized components.
- Before connecting a power cable, check that the label on the power cable is correct.
- If the equipment has multiple inputs, disconnect all the inputs before operating the equipment.

## Cabling

- When routing cables, ensure that a distance of at least 30 mm exists between the cables and heat-generating components or areas. This prevents damage to the insulation layer of the cables.
- Bind cables of the same type together. When routing cables of different types, ensure that they are at least 30 mm away from each other.
- Ensure that the cables used in a grid-tied PV power system are properly connected and insulated and meet specifications.

## 1.4 Installation Environment Requirements

- Ensure that the equipment is installed in a well ventilated environment.
- To prevent fire due to high temperature, ensure that the ventilation vents or heat dissipation system are not blocked when the equipment is running.
- Do not expose the equipment to flammable or explosive gas or smoke. Do not perform any operation on the equipment in such environments.

## 1.5 Mechanical Safety

### Using Ladders

- Use wooden or fiberglass ladders when you need to perform live working at heights.
- When a step ladder is used, ensure that the pull ropes are secured and the ladder is held firm.
- Before using a ladder, check that it is intact and confirm its load bearing capacity. Do not overload it.
- Ensure that the wider end of the ladder is at the bottom, or protective measures have been taken at the bottom to prevent the ladder from sliding.
- Ensure that the ladder is securely positioned. The recommended angle for a ladder against the floor is 75 degrees, as shown in the following figure. An angle rule can be used to measure the angle.

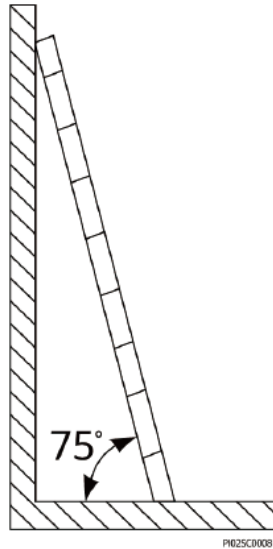

- When climbing a ladder, take the following precautions to reduce risks and ensure safety:
  - Keep your body steady.
  - Do not climb higher than the fourth rung of the ladder from the top.
  - Ensure that your body's center of gravity does not shift outside the legs of the ladder.

## Drilling Holes

When drilling holes into a wall or floor, observe the following safety precautions:

- Wear goggles and protective gloves when drilling holes.
- When drilling holes, protect the equipment from shavings. After drilling, clean up any shavings that have accumulated inside or outside the equipment.

## Moving Heavy Objects

- Be cautious to avoid injury when moving heavy objects.

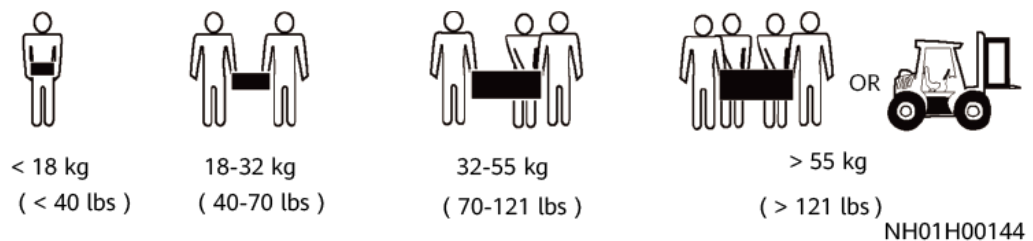

- When moving the equipment by hand, wear protective gloves to prevent injuries.

## 1.6 Commissioning

When the equipment is powered on for the first time, ensure that professional personnel set parameters correctly. Incorrect settings may result in inconsistency with local certification and affect the normal operation of the equipment.

## 1.7 Maintenance and Replacement

---

 **DANGER**

High voltage generated by the equipment during operation may cause an electric shock, which could result in death, serious injury, or serious property damage. Prior to maintenance, power off the equipment and strictly comply with the safety precautions in this document and relevant documents.

- 
- Maintain the equipment with sufficient knowledge of this document and using proper tools and testing equipment.
  - Before maintaining the equipment, power it off and follow the instructions on the delayed discharge label to ensure that the equipment is powered off.
  - Place temporary warning signs or erect fences to prevent unauthorized access to the maintenance site.
  - If the equipment is faulty, contact your dealer.
  - The equipment can be powered on only after all faults are rectified. Failing to do so may escalate faults or damage the equipment.

# 2 Overview

## 2.1 Product Overview

### Function

The SUN2000 inverter is a three-phase grid-tied PV string inverter that converts the DC power generated by PV strings into AC power and feeds the power into the power grid.

### Model

This document involves the following product models:

- SUN2000-175KTL-H0
- SUN2000-185KTL-INH0
- SUN2000-185KTL-H1

**Figure 2-1** Model description (SUN2000-185KTL-INH0 is used as an example)

SUN2000-185KTL-INH0

1                      2                      3                      4                      5

**Table 2-1** Model description

Tag	Meaning	Value
1	Series	SUN2000: three-phase grid-tied PV string inverter

Tag	Meaning	Value
2	Power class	<ul style="list-style-type: none"> <li>175K: The rated output power is 175 kW.</li> <li>185K: The maximum active power is 185 kW.</li> </ul>
3	Topology	TL: transformerless
4	Region	IN: India
5	Product code	H0/H1: product series with the 1500 V DC input voltage

**NOTE**

The SUN2000-175KTL-H0 is applicable only to the Chinese mainland. For other countries or regions, Huawei does not provide quality assurance.

## Network Application

The inverter applies to grid-tied PV systems for commercial rooftop PV plants and large PV plants. Typically, a grid-tied PV system consists of the PV string, inverter, AC power distribution unit, and step-up transformer.

**Figure 2-2** Network application

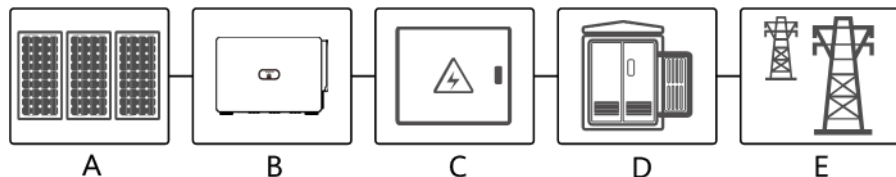

(A) PV string

(B) Inverter

(C) AC distribution unit (ACDU)

(D) Step-up transformer

(E) Power grid

**NOTE**

The SUN2000 is powered by a dedicated power transformer instead of connecting to low voltage overhead power lines.

## Supported Power Grid

The inverter supports the IT power grid.

**Figure 2-3** Supported power grid

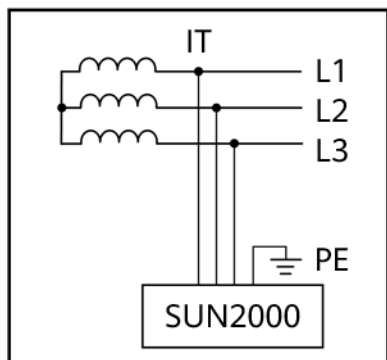

**NOTE**

The SUN2000 can also apply to the AC power system with the neutral point grounding of the step-up transformer. The SUN2000 itself does not connect to any neutral wire.

**Figure 2-4** AC power system with the neutral point grounding

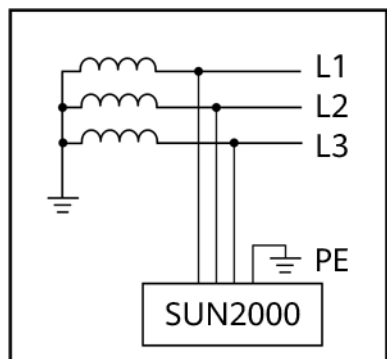

## 2.2 Appearance

### Dimensions

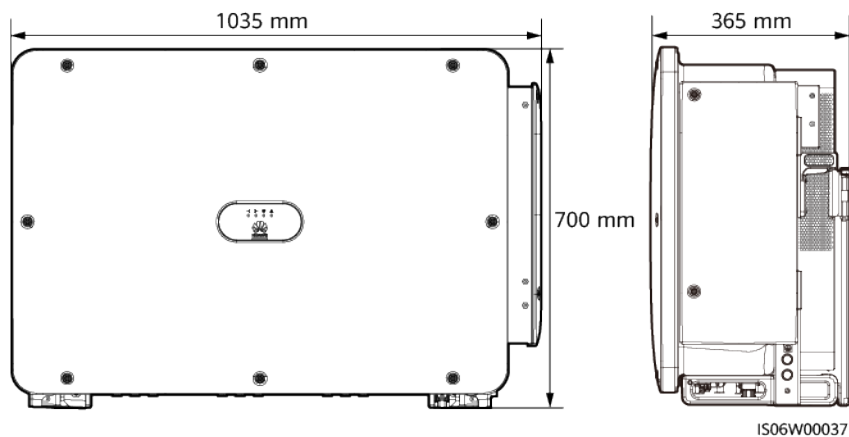

## Front View

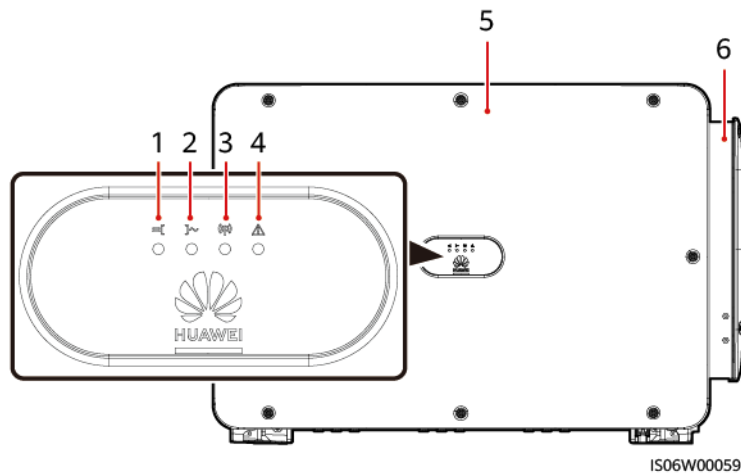

- |                                 |                         |                             |
|---------------------------------|-------------------------|-----------------------------|
| (1) PV connection indicator     | (2) Grid-tied indicator | (3) Communication indicator |
| (4) Alarm/Maintenance indicator | (5) Host panel          | (6) Maintenance compartment |

**Table 2-2** LED description

Display Category	Indicator Status		Meaning
PV indication  LED1      LED4	LED1	LED4	-
	Steady green	-	At least one PV string is properly connected, and the DC input voltage of the corresponding MPPT circuit is at least 500 V.
	Blinking green at short intervals	Red	An environmental fault occurs at DC side.
	Off	-	The inverter disconnects from all PV strings, or the DC input voltage of all MPPT circuits is less than 500 V.
Grid-tied indication  LED2      LED4	LED2	LED4	NA
	Steady green	-	The inverter is in grid-tied mode.
	Blinking green at short intervals	Red	An environmental fault occurs at AC side.

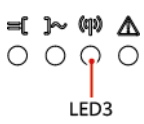
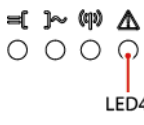
Display Category	Indicator Status		Meaning
	Off	-	The inverter is not in grid-tied mode.
Communications indication 	LED3	-	-
	Blinking green at short intervals		The inverter receives data over RS485 or MBUS communication.
	Off		The inverter has not received data over RS485 or MBUS communication for 10 seconds.
Alarm/O&M indication 	LED4	-	-
	Steady red		A major alarm is generated. If the PV connection indicator and grid connection indicator are both not blinking green fast, replace components or the solar inverter as instructed by the SUN2000 app.
	Blinking red at short intervals		A minor alarm is generated.
	Blinking red at long intervals		A warning alarm is generated.
	Steady green		Local maintenance succeeds.
	Blinking green at long intervals		In local maintenance or shuts down over a command.
	Blinking green at short intervals		Local maintenance fails.
	Off		No alarm is generated, and no local maintenance operations are performed.

 **NOTE**

- Local maintenance refers to operations performed after a universal serial bus (USB) flash drive, Bluetooth module, WLAN module, or USB data cable is inserted into the USB port of the inverter. For example, local maintenance includes configuration import and export using a USB flash drive, and connecting to the SUN2000 app over a Bluetooth module, WLAN module, or USB data cable.
- If the alarming and the local maintenance happen concurrently, the alarm/maintenance indicator shows the local maintenance state first. After the USB flash drive, Bluetooth module, WLAN module, or USB data cable is removed, the indicator shows the alarm state.

## Bottom View

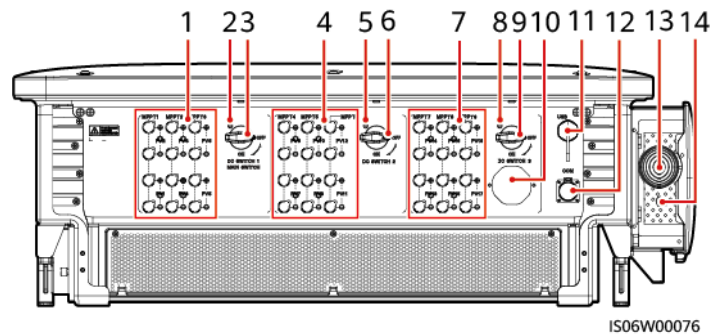

- |  |  |
|--|--|
| (1) DC input terminals (controlled by DC SWITCH 1) | (2) Screw hole for DC switch 1                     |
| (3) DC switch 1 (DC SWITCH 1)                      | (4) DC input terminals (controlled by DC SWITCH 2) |
| (5) Screw hole for DC switch 2                     | (6) DC switch 2 (DC SWITCH 2)                      |
| (7) DC input terminals (controlled by DC SWITCH 3) | (8) Screw hole for DC switch 3                     |
| (9) DC switch 3 (DC SWITCH 3)                      | (10) Ventilation valve                             |
| (11) USB port (USB)                                | (12) Communications port (COM)                     |
| (13) Hole for the AC output power cable            | (14) Hole for the tracking system power cable      |









### NOTE

The screw hole for DC switch is provided only for the models used in Australia.

## 2.3 Label Description

### 2.3.1 Label Description

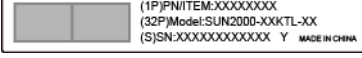
Symbol	Name	Meaning
	Running warning	Potential hazards exist after the inverter is powered on. Take protective measures when operating the inverter.
	Burn warning	Do not touch a running inverter, as the shell becomes hot during operation.

Symbol	Name	Meaning
	Large current warning	Before powering on the inverter, ensure that the inverter is grounded because there is a large contact current after the inverter is powered on.
	Delayed discharge	<ul style="list-style-type: none"> <li>High voltage exists after the inverter is powered on. Only qualified and trained electrical technicians are allowed to perform operations on the inverter.</li> <li>Residual voltage exists after the inverter is powered off. It takes 15 minutes for the inverter to discharge to the safe voltage.</li> </ul>
	Refer to documentation	Reminds operators to refer to the documents shipped with the inverter.
	Grounding	Indicates the position for connecting the protective earthing (PE) cable.
	Operation warning	Do not remove the DC input connector when the inverter is running.
	Fan operation warning	High voltage exists after the inverter is powered on. Do not touch the fans when the inverter is working.
	Fan replacement warning	Before replacing a fan, disconnect its power connectors.
	Inverter ESN label	Indicates the inverter serial number.
	Weight label	The inverter needs to be carried by four persons or using a pallet truck.

## 2.3.2 Product Nameplate

Figure 2-5 Nameplate (SUN2000-175KTL-H0 is used as an example)

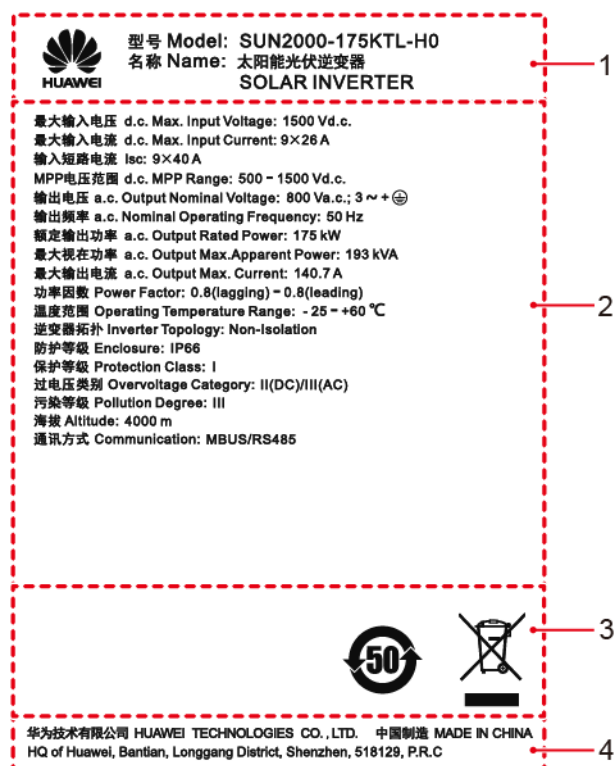

- (1) Trademark and product model
- (2) Important technical specifications
- (3) Compliance symbols
- (4) Company name and country of manufacture

NOTE

The nameplate figure is for reference only.

## 2.4 Working Principles

### 2.4.1 Circuit Diagram

The inverter receives inputs from 18 PV strings. Then the inputs are grouped into nine MPPT circuits inside the inverter to track the maximum power point of the PV strings. The DC power is then converted into three-phase AC power through an inverter circuit. Surge protection is supported on both the DC and AC sides.

Figure 2-6 Inverter conceptual diagram

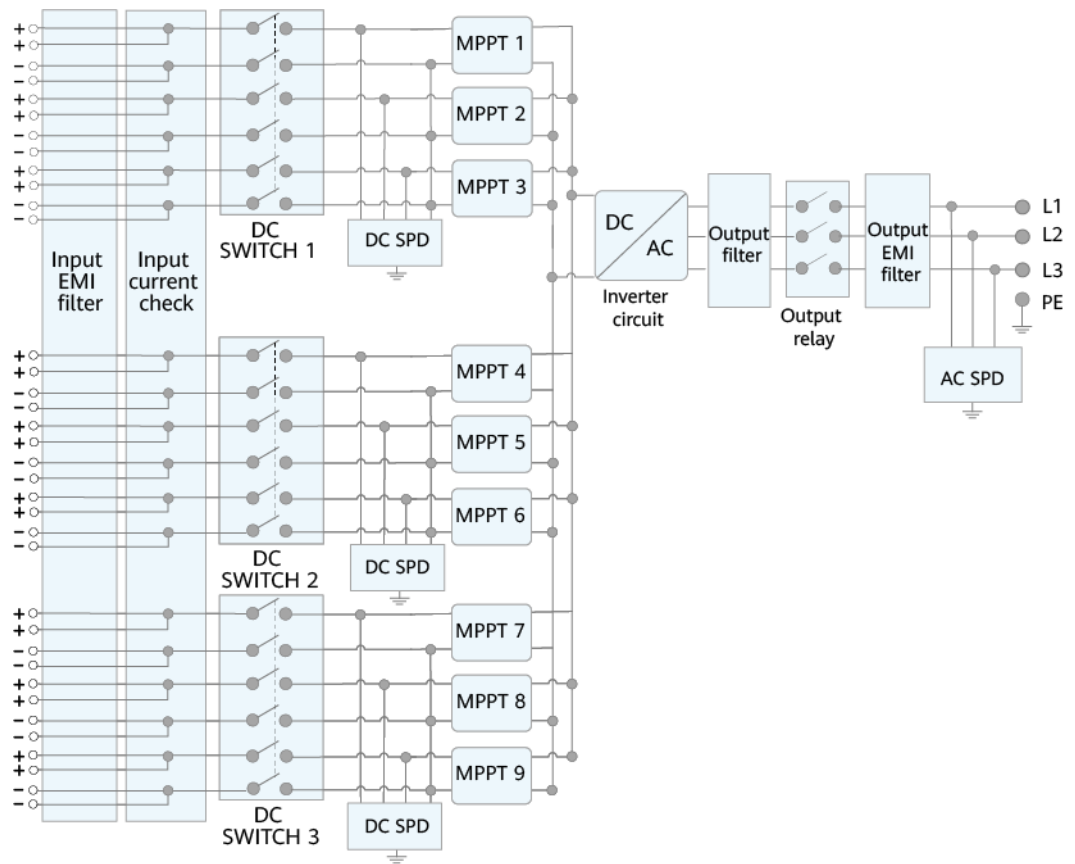

IS06P00001

## 2.4.2 Working Modes

The SUN2000 can work in Standby, Operating, or Shutdown mode.

Figure 2-7 Working modes

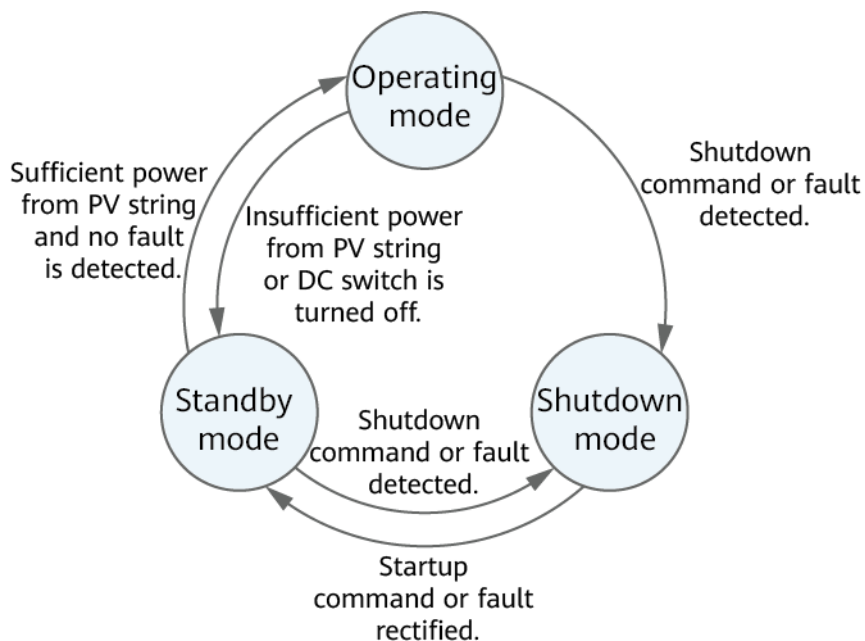

IS07500001

Table 2-3 Working mode description

Working Mode	Description
Standby	<p>The SUN2000 enters Standby mode when the external environment does not meet the operating requirements. In Standby mode:</p> <ul style="list-style-type: none"> <li>• The SUN2000 continuously performs status check and enters the Operating mode once the operating requirements are met.</li> <li>• The SUN2000 enters Shutdown mode after detecting a shutdown command or a fault after startup.</li> </ul>
Operating	<p>In Operating mode:</p> <ul style="list-style-type: none"> <li>• The SUN2000 converts DC power from PV strings into AC power and feeds the power to the power grid.</li> <li>• The SUN2000 tracks the maximum power point to maximize the PV string output.</li> <li>• If the SUN2000 detects a fault or a shutdown command, it enters the Shutdown mode.</li> <li>• The SUN2000 enters Standby mode after detecting that the PV string output power is not suitable for connecting to the power grid for generating power.</li> </ul>
Shutdown	<ul style="list-style-type: none"> <li>• In Standby or Operating mode, the SUN2000 enters Shutdown mode after detecting a fault or shutdown command.</li> <li>• In Shutdown mode, the SUN2000 enters Standby mode after detecting a startup command or that the fault is rectified.</li> </ul>

# 3 Solar Inverter Storage

The following requirements should be met if the solar inverter is not put into use immediately:

- Do not remove the packing materials, and check the packing materials regularly (recommended: every three months). If any rodent bites are found, replace the packing materials immediately. If the solar inverter is unpacked but not put into use immediately, put it inside the original package with the desiccant bag, and seal it using tape.
- The ambient temperature and humidity should be suitable for the storage. The air must not contain corrosive or flammable gases.

**Figure 3-1** Storage temperature and humidity

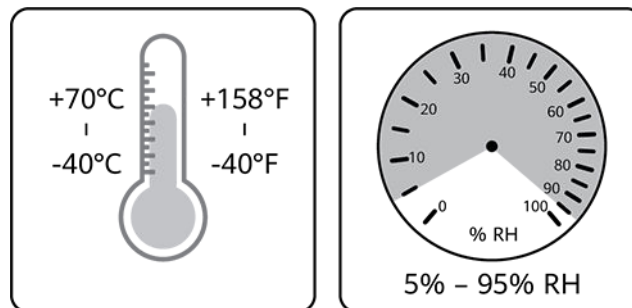

IS07W00011

- The solar inverter should be stored in a clean and dry place and be protected from dust and water vapor corrosion. The solar inverter must be protected against rain and water.
- Do not tilt the package or place it upside down.
- To avoid personal injury or device damage, stack inverters with caution to prevent them from falling over.

**Figure 3-2** Maximum number of pile-up layers allowed

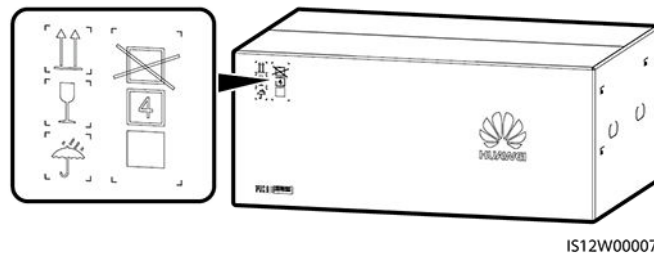

- If the solar inverter has been stored for more than two years, it must be checked and tested by professionals before being put into use.

# 4 Installation

---

## 4.1 Checking Before Installation

### Outer Packing Materials

Before unpacking the inverter, check the outer packing materials for damage, such as holes and cracks, and check the inverter model. If any damage is found or the inverter model is not what you requested, do not unpack the package and contact your supplier as soon as possible.

 **NOTE**

You are advised to remove the packing materials within 24 hours before installing the inverter.









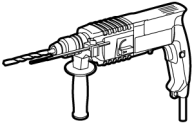
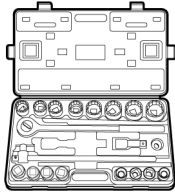
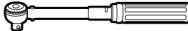
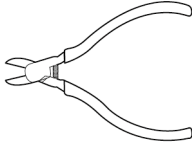
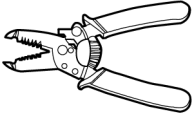

### Package Contents

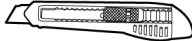



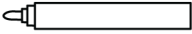
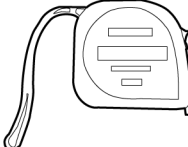

After unpacking the inverter, check that the contents are intact and complete. If any damage is found or any component is missing, contact your supplier.

 **NOTE**

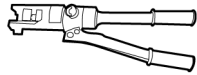
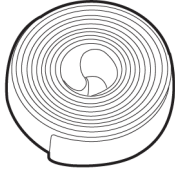
For details about the number of contents, see the *Packing List* in the packing case.

## 4.2 Preparing Tools

Type	Tool			
Installation tools	 Hammer drill Drill bit: $\Phi 14$ mm and $\Phi 16$ mm	 Socket wrench set	 Torque wrench	 Diagonal pliers
	 Wire stripper	 Flat-head screwdriver Head: 0.6 mm x 3.5 mm	 Rubber mallet	 Utility knife
	 Cable cutter	 Crimping tool Model: PV-CZM-41100; manufacturer: Staubli	 Removal wrench Model: 13001462; manufacturer: Staubli	 Vacuum cleaner
	 Multimeter DC voltage measurement range $\geq 1500$ V DC	 Marker	 Measuring tape	 Bubble or digital level

Type	Tool			
	 Hydraulic pliers	 Heat shrink tubing	 Heat gun	 Binding strap
Personal protective equipment (PPE)	 Safety gloves	 Safety goggles	 Anti-dust respirator	 Safety boots

## 4.3 Determining the Installation Position

### 4.3.1 Environment Requirements

#### Basic Requirements

- Do not install the inverter in working or living areas.
- If the device is installed in public places (such as parking lots, stations, and factories) other than working and living areas, install a protective net outside the device, set up a safety warning sign to isolate the device, and prevent unauthorized personnel from approaching the inverter. This is to avoid personal injury or property loss caused by accidental contact or other reasons during device operation.
- Do not install the inverter in areas with flammable materials.
- Do not install the inverter in areas with explosive materials.
- Do not install the inverter in areas with corrosive materials.
- Do not install the inverter where its enclosure and heat sinks are easily accessible, because the voltage is high and these parts are hot during operation.
- Install the inverter in a well-ventilated environment for heat dissipation
- If the inverter is installed in an airtight environment, a heat dissipation device or ventilation device must be installed to ensure that the indoor ambient temperature is not higher than the external ambient temperature during operation.
- You are advised to install the inverter in a sheltered place or install an awning over it.
- The inverter will be corroded in salt areas. Before installing the inverter outdoors in salt areas, consult Huawei. A salt area refers to the region within

500 meters from the coast or prone to sea breeze. The regions prone to sea breeze vary with weather conditions (such as typhoons and monsoons) or terrains (such as dams and hills).

### Mounting Structure Requirements

- The mounting structure where the inverter is installed must be fire resistant.
- Do not install the inverter on flammable building materials.
- The inverter is heavy. Ensure that the installation surface is solid enough to bear the weight load.
- In residential areas, do not install the inverter on drywalls or walls made of similar materials which have a weak sound insulation performance because the noise generated by the inverter is noticeable.

Figure 4-1 Mounting structure

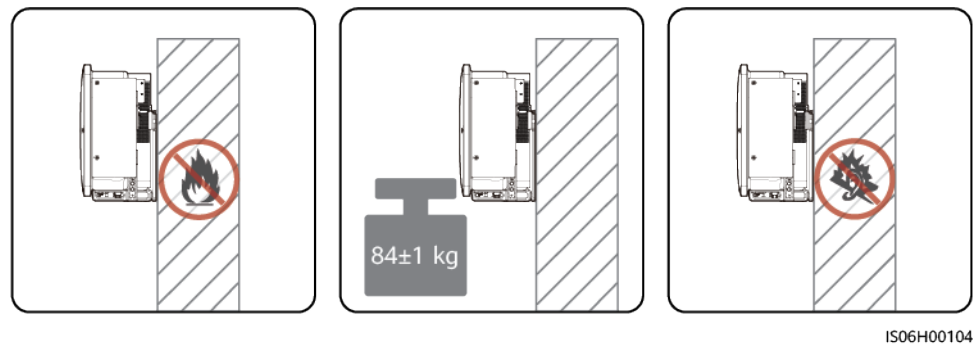

### 4.3.2 Space Requirements

- Reserve enough clearance around the inverter and select an appropriate installation angle to ensure sufficient space for installation and heat dissipation.

Figure 4-2 Installation space

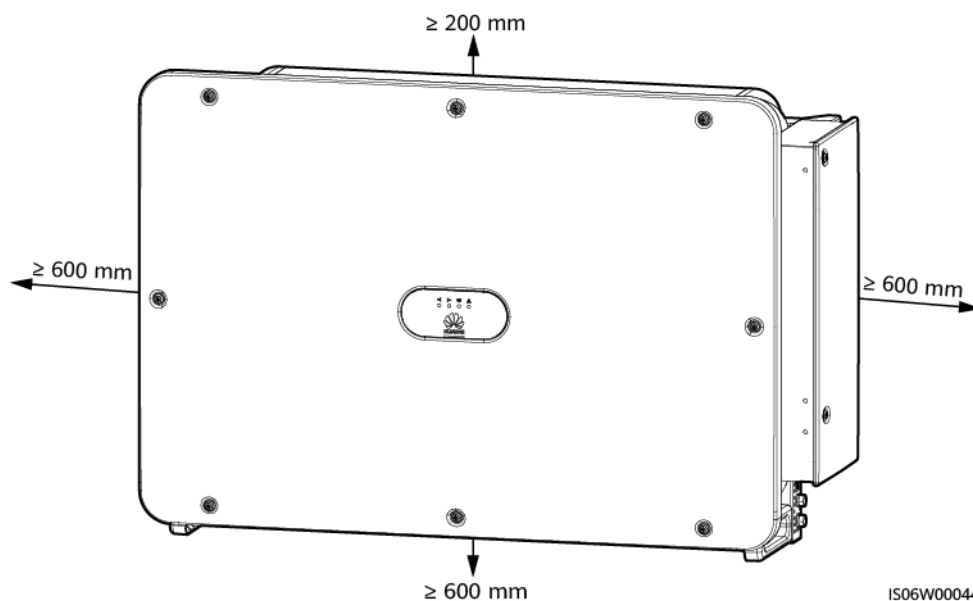

 NOTE

For ease of installing the inverter on the mounting bracket, connecting cables to the bottom of the inverter, and maintaining the inverter in future, it is recommended that the bottom clearance be between 600 mm and 730 mm. If you have any question about the clearance, consult the local technical support engineers.

**Figure 4-3** Installation angle

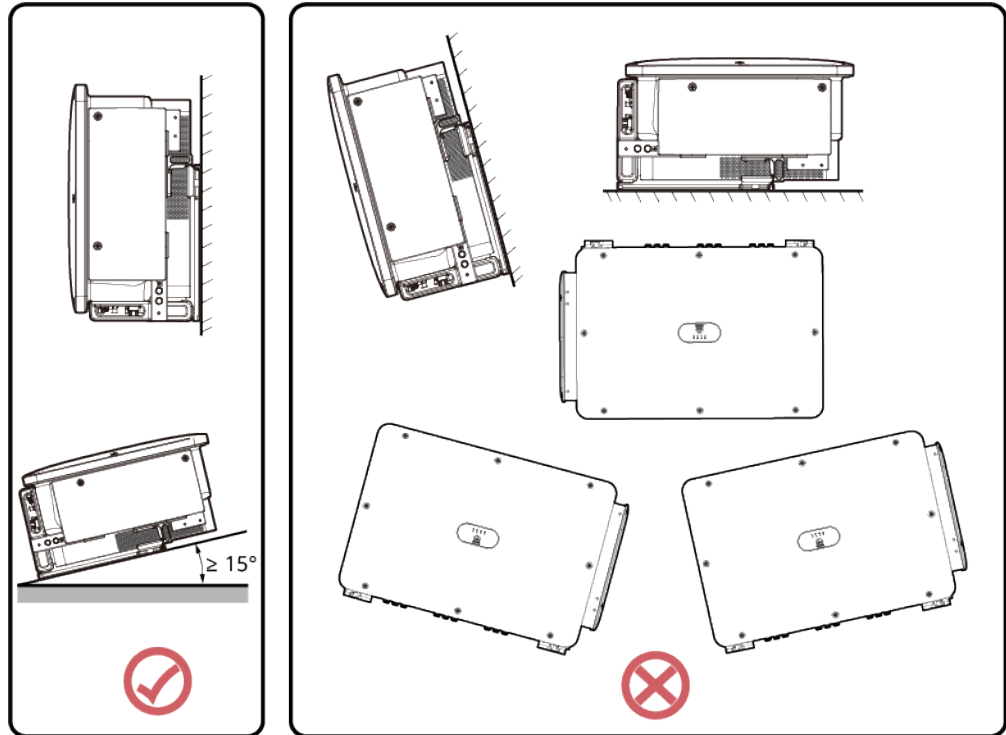

IS06W00043

- When installing multiple inverters, install them in horizontal mode if sufficient space is available and install them in triangle mode if no sufficient space is available. Stacked installation is not recommended.

**Figure 4-4** Horizontal installation mode (recommended)

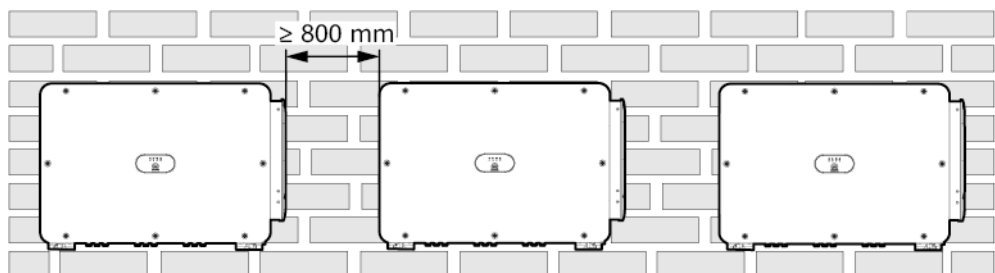

IS06W00046

**Figure 4-5** Triangle installation mode (recommended)

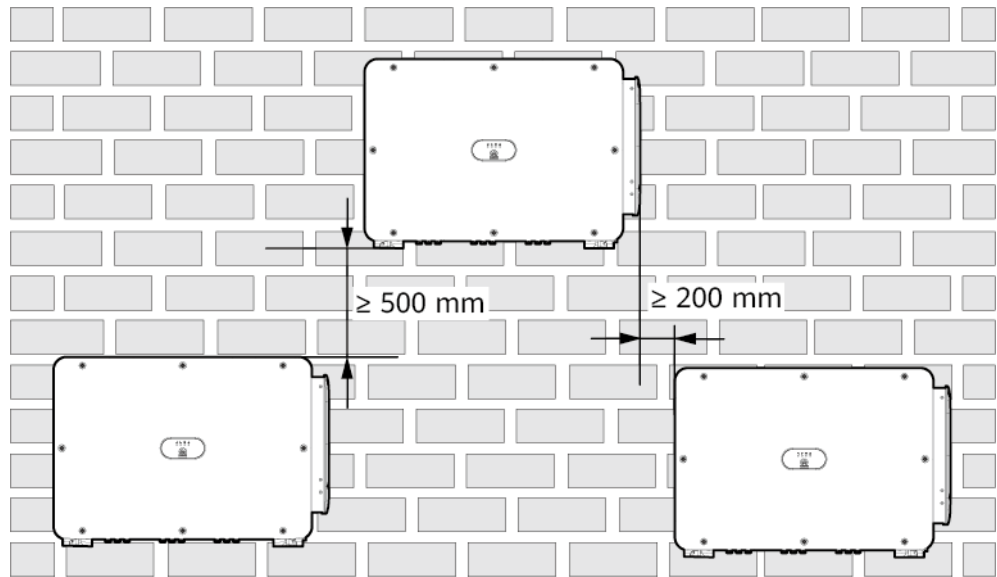

IS06W00047

**Figure 4-6** Stacked installation mode (not recommended)

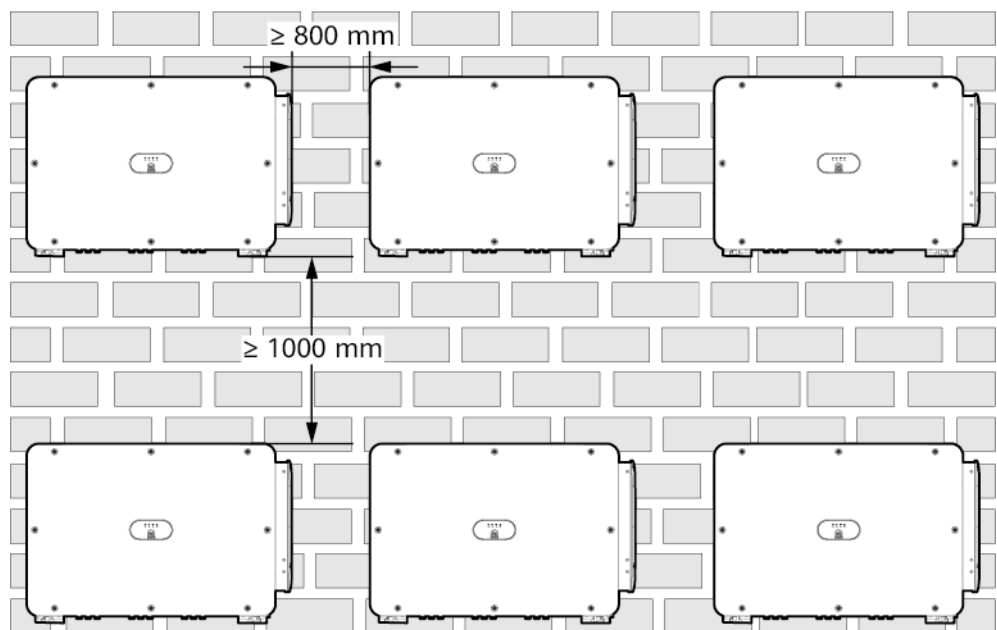

IS06W00048

## 4.4 Installing the Mounting Bracket

### Installation Precautions

**Figure 4-7** shows the inverter mounting bracket dimensions.

**Figure 4-7** Mounting bracket dimensions

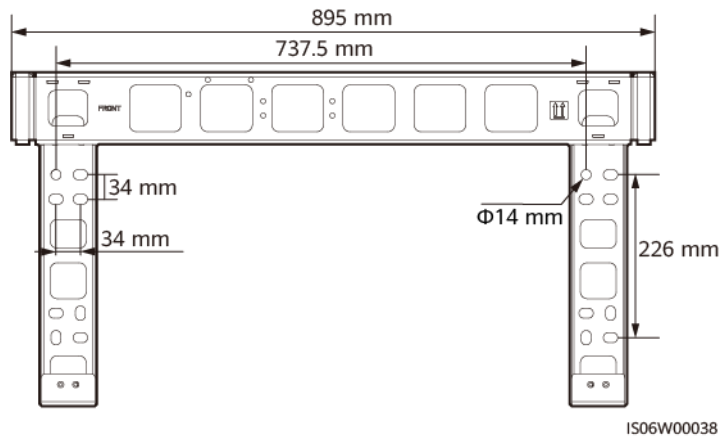

**NOTE**

The inverter mounting bracket has four groups of tapped holes, each group containing four tapped holes. Mark any hole in each group based on site requirements and mark four holes in total. The two round holes are recommended.

Before installing the mounting bracket, remove the security torx wrench from the mounting bracket and set it aside.

**Figure 4-8** Removing a security torx wrench

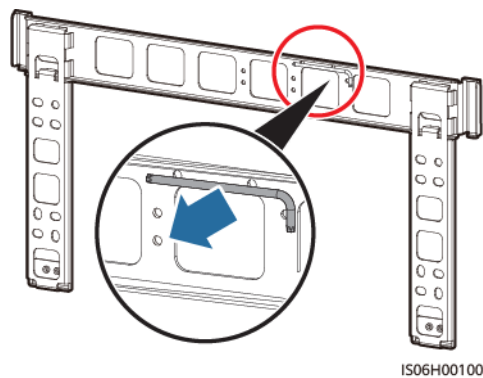

## 4.4.1 Support-mounted Installation

### Support-mounted Installation

**Step 1** Install the mounting bracket.

**Figure 4-9** Installing the mounting bracket

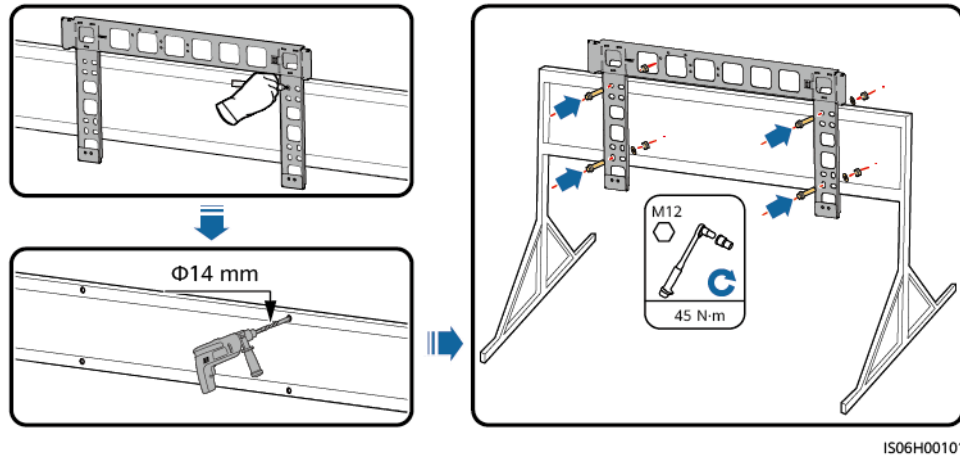

**NOTE**

The M12x40 bolt assemblies are delivered with the SUN2000 (bound to the mounting bracket). If the bolt assembly length does not meet the installation requirements, prepare M12 bolt assemblies by yourself and use them together with the delivered M12 nuts.

----End

## 4.4.2 Wall-mounted Installation

### Wall-mounted Installation

**Step 1** Install the mounting bracket.

**WARNING**

Avoid drilling holes in the water pipes and power cables buried in the wall.

**NOTICE**

- To prevent dust inhalation or contact with eyes, wear safety goggles and an anti-dust respirator when drilling holes.
- Clean up any dust in and around the holes using a vacuum cleaner and measure the distance between holes. If the holes are inaccurately positioned, drill a new set of holes.
- Level the head of the expansion sleeve with the concrete wall after removing the bolt, spring washer, and flat washer. Otherwise, the mounting bracket will not be securely installed on the wall.

**Figure 4-10** Securing the mounting bracket

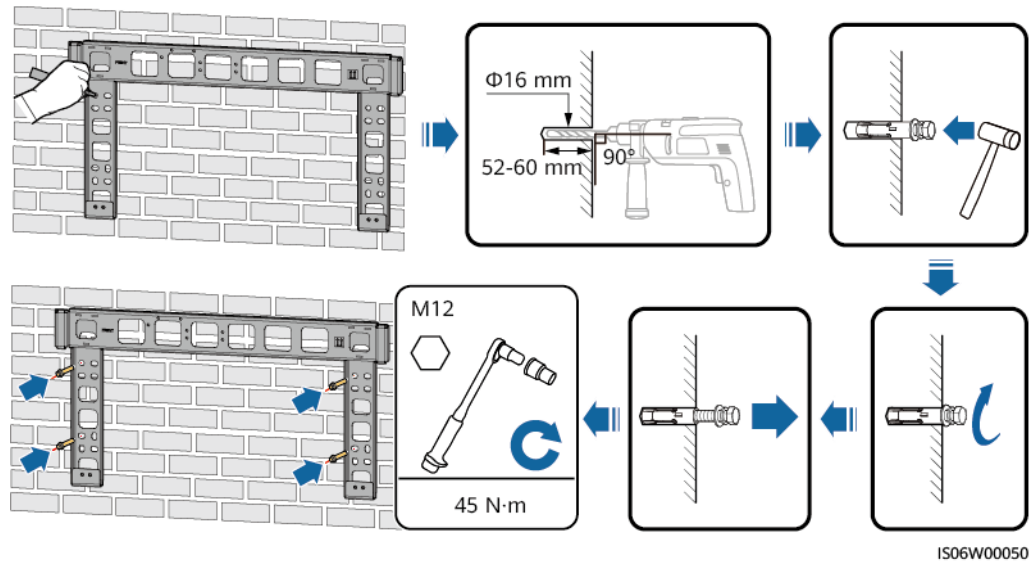

----End

## 4.5 Installing the Inverter

### Preparing for the Installation

Before installing the inverter, take it out from the packing case and move it to the installation position.

**NOTE**

Handles are packed in a fitting bag and are not delivered with the inverter.

**Figure 4-11** Taking out and moving the inverter

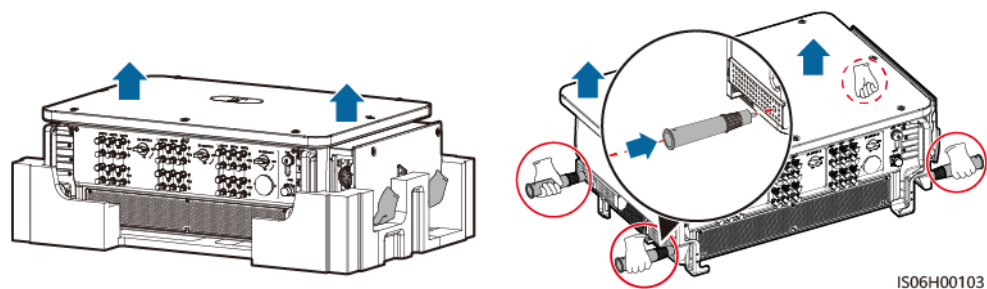

**NOTICE**

- Move the inverter with the help of other three persons or using an appropriate transportation tool.
- Do not place the inverter with its wiring terminals at the bottom contacting the floor or any other objects because the terminals are not designed to bear the weight of the inverter.
- When you need to temporarily place the inverter on the ground, use foam, paper, or other protection material to prevent damage to its cover.
- Do not lift or hoist the inverter using the bottom holes of the handles to prevent the handles from cracking.

**Figure 4-12** Lifting positions

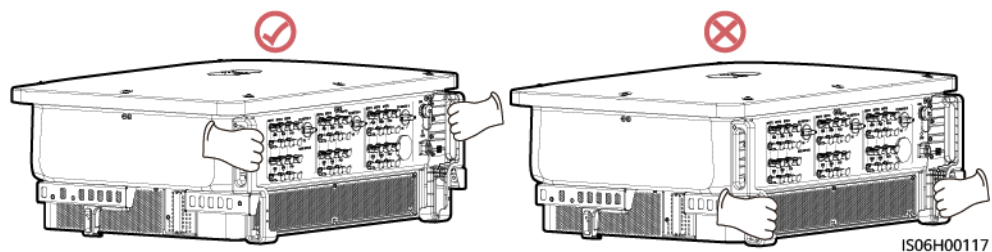

## Installing the Inverter

**Step 1 Optional:** Install screws for locking DC switches.

 **NOTE**

For the model used in Australia, perform this step to meet the local standards.

**Figure 4-13** Install screws for locking DC switches

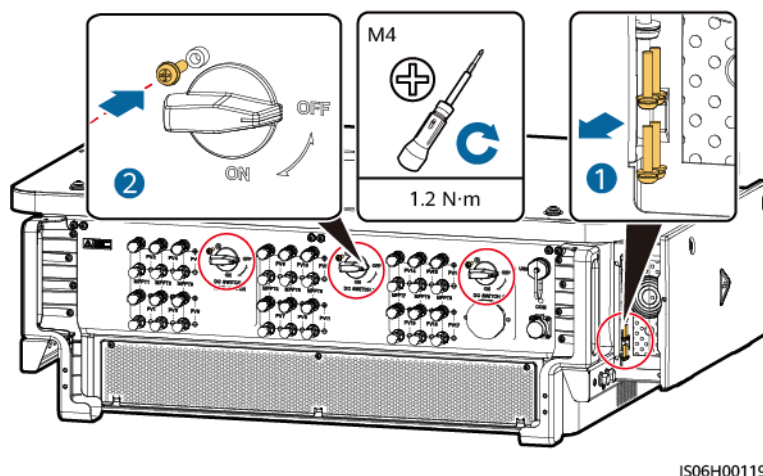

**Step 2** Mount the inverter on the mounting bracket.

**Step 3** Tighten the two screws at the bottom of the inverter.

Figure 4-14 Installation

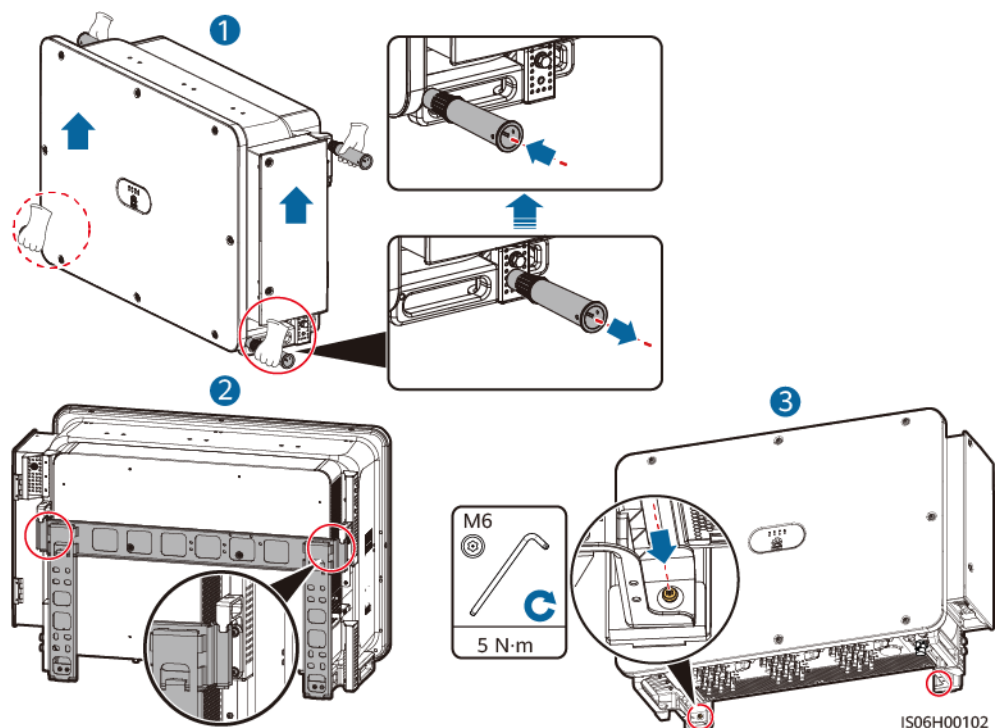

----End

## Supplementary Notes

If the inverter is installed in a high position, you can hoist it.

Figure 4-15 Hoisting the inverter

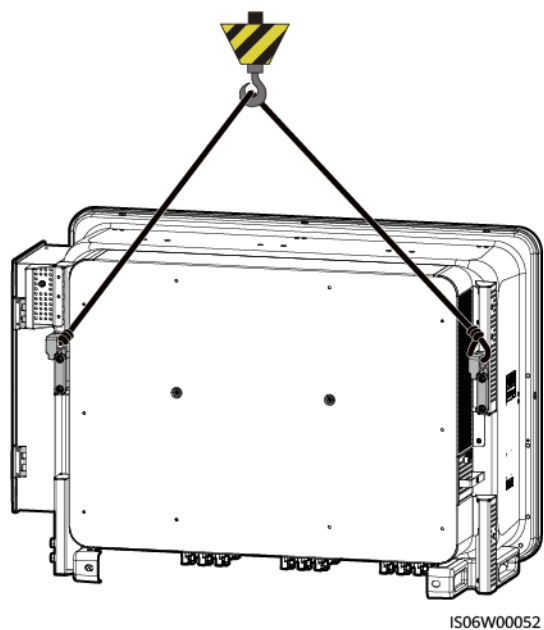

# 5 Electrical Connections

---

## 5.1 Precautions

---

 **DANGER**

Before connecting cables, ensure that all DC switches on the inverter are OFF. Otherwise, the high voltage of the inverter may result in electric shocks.

---

---

 **WARNING**

- The device damage caused by incorrect cable connections is beyond the warranty scope.
  - Only qualified technicians can perform operations about electrical connection.
  - Wear proper PPE at all time when connecting cables.
- 

 **NOTE**

The cable colors shown in the electrical connection diagrams provided in this chapter are for reference only. Select cables in accordance with local cable specifications (green-and-yellow cables are only used for protective earthing).

## 5.2 Crimping an OT or DT Terminal

### Requirements for the OT or DT Terminal

- If a copper cable is used, use copper wiring terminals.
- If a copper-clad aluminum cable is used, use copper wiring terminals.
- If an aluminum alloy cable is used, use copper-aluminum transition wiring terminals, or aluminum wiring terminals along with copper-aluminum transition spacers.

**NOTICE**

- Do not connect aluminum wiring terminals to the AC terminal block. Otherwise the electrochemical corrosion will occur and affect the reliability of cable connections.
- Comply with the IEC61238-1 requirements when using copper-aluminum transition wiring terminals, or aluminum wiring terminals along with copper-aluminum transition spacers.
- If copper-aluminum transition spacers are used, pay attention to the front and rear sides. Ensure that the aluminum sides of spacers are in contact with aluminum wiring terminals, and copper sides of spacers are in contact with the AC terminal block.

**Figure 5-1** Requirements for the OT/DT terminal

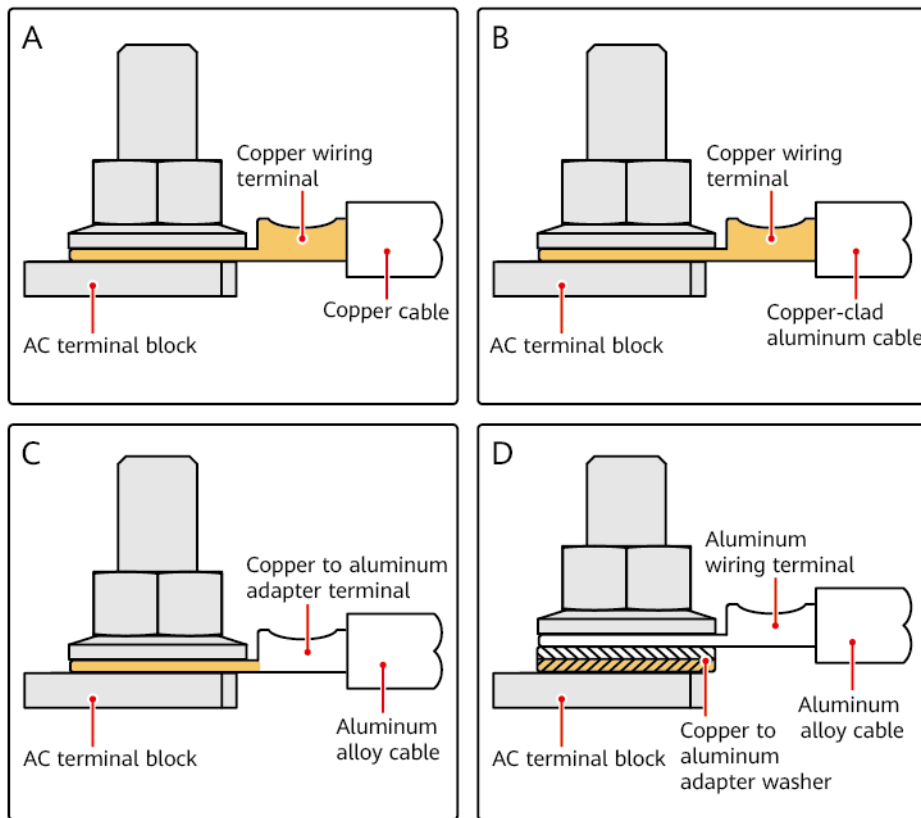

IS03H00062

## Crimping an OT or DT Terminal

### NOTICE

- Pay attention not to scratch the core wire when stripping a cable.
- The cavity formed after the conductor crimp strip of the OT or DT terminal is crimped must wrap the core wires completely. The core wires must contact the OT or DT terminal closely.
- Wrap the wire crimping area with a heat shrink tubing or PVC insulation tape. The heat shrink tubing is used as an example.
- When using a heat gun, protect devices from being scorched.

Figure 5-2 Crimping an OT terminal

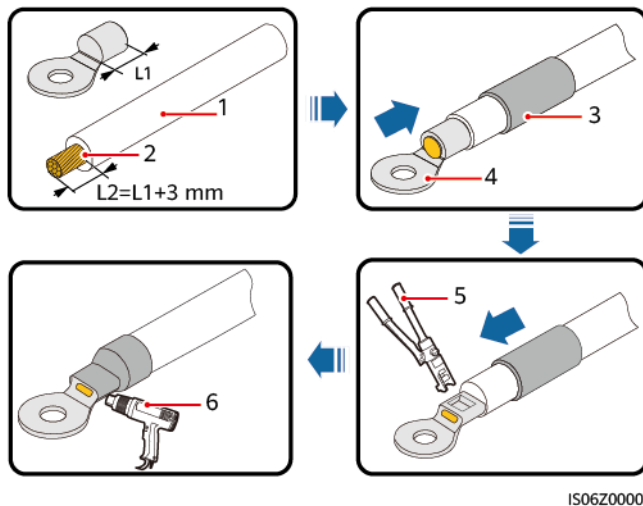

(1) Cable

(2) Core

(3) Heat shrink tubing

(4) OT terminal

(5) Hydraulic pliers

(6) Heat gun

Figure 5-3 Crimping a DT terminal

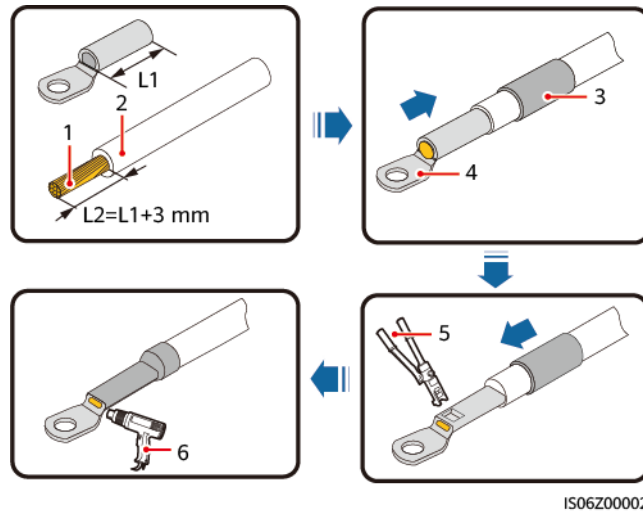

- |                 |                      |                        |
|-----------------|----------------------|------------------------|
| (1) Cable       | (2) Core             | (3) Heat shrink tubing |
| (4) DT terminal | (5) Hydraulic pliers | (6) Heat gun           |

## 5.3 Opening the Maintenance Compartment Door

### Precautions

#### NOTICE

- Do not open the host panel cover of the inverter.
- Before opening the maintenance compartment door, ensure that no electrical connections are made for the inverter on the AC or DC side.
- If you need to open the maintenance compartment door in rainy or snowy days, take protective measures to prevent rain or snow entering the maintenance compartment. If unavoidable, do not open the maintenance compartment door.
- Do not leave unused screws in the maintenance compartment.

### Procedure

- Step 1** Partially loosen the two screws on the maintenance compartment door.
- Step 2** Open the maintenance compartment door and install a support bar.

**Figure 5-4** Opening the maintenance compartment door

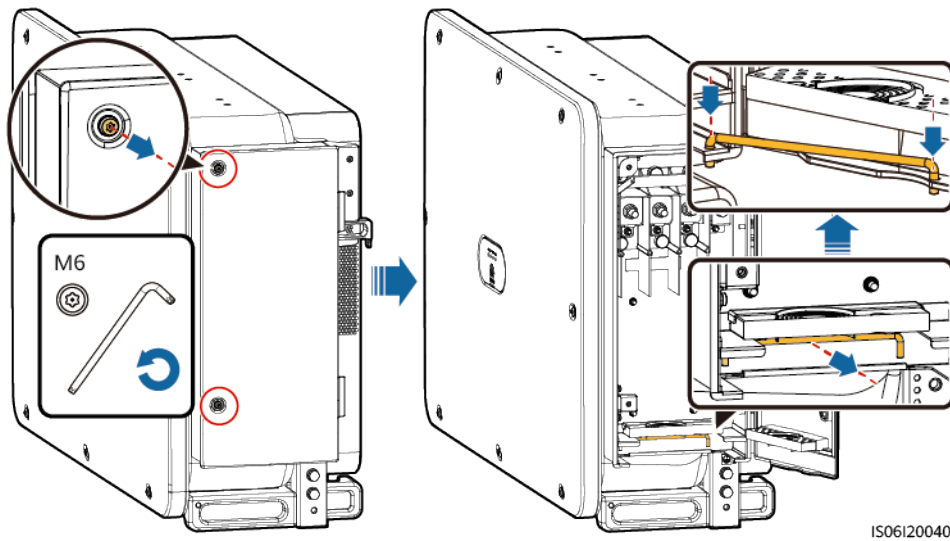

IS06I20040

**Step 3** Remove the accessories that are bound in the maintenance compartment for future use.

**NOTE**

For some models, a three-hole rubber plug is bound in the maintenance compartment. After removing the rubber plug, save it properly for future use

**Figure 5-5** Removing the accessories from the maintenance compartment

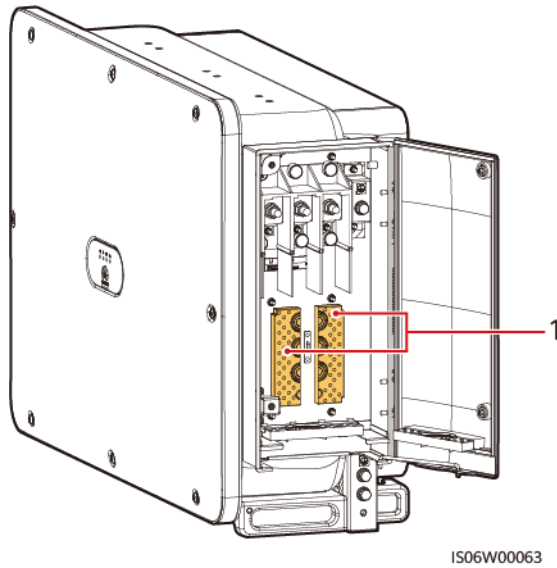

(1) Crimping modules

----End

## 5.4 (Optional) Replacing the Crimping Module

### Procedure

 NOTE

If the AC output power cable has a single core, replace the crimping module.

**Step 1** Replace the crimping module.

**Figure 5-6** Replacing the crimping module

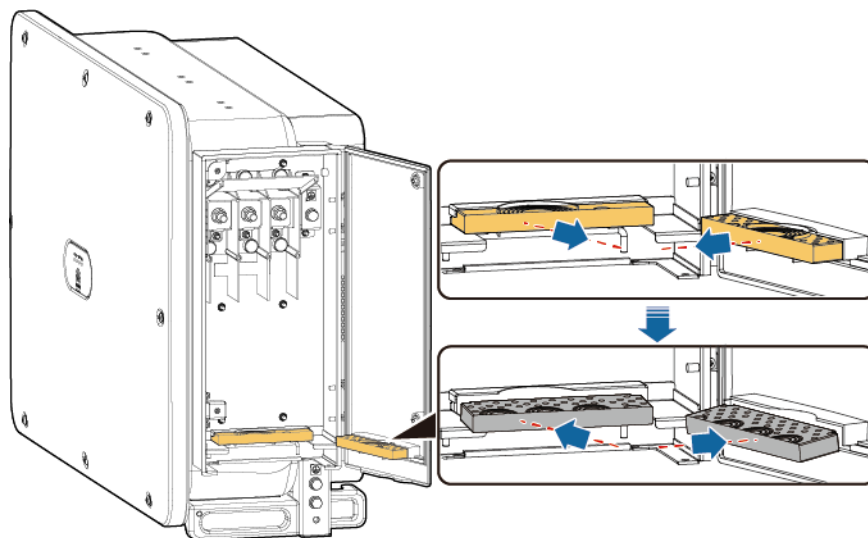

IS06I20047

----End

## 5.5 (Optional) Installing the Power Cable of the Tracking System

### Precautions

**NOTICE**

- A switch-disconnector-fuse or fuse-switch-disconnector with a voltage of no less than 800 V, current of 16 A, and protection type of gM needs to be installed between the inverter and the tracker controller for protection.
- The cable between the wiring terminal on the power cable and the switch-disconnector-fuse or fuse-switch-disconnector should be less than or equal to 2.5 m.
- Connect the power cable of the tracking system before the AC output power cable. Otherwise, reworking will be caused.

## Cable Specifications

Recommended: dual-layer three-core outdoor copper cable with a conductor cross-sectional area of  $10 \text{ mm}^2$  and a cable outer diameter of 15–18 mm.

## Procedure

**Step 1** Connect the power cable of the tracking system to the terminal block.

**Figure 5-7** Cable connection

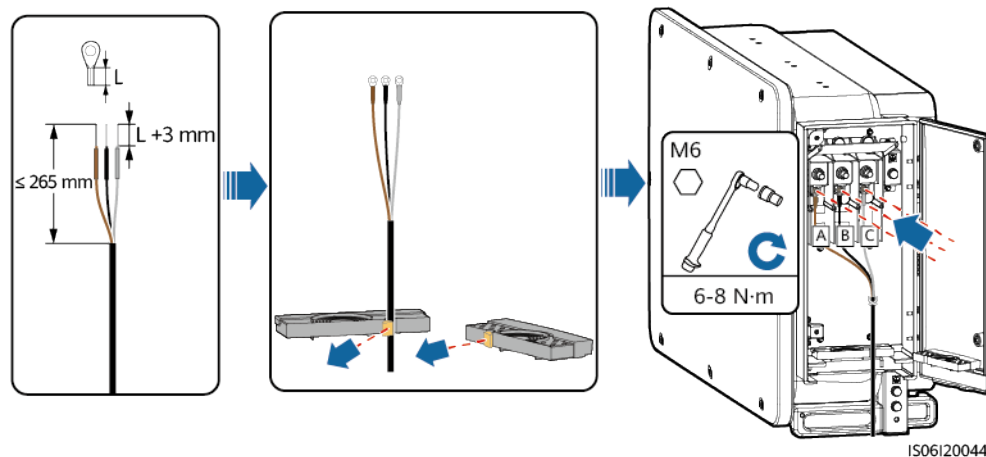

----End

## 5.6 Connecting the AC Output Power Cable

### Precautions

A three-phase AC switch should be installed on the AC side of the inverter. To ensure that the inverter can safely disconnect itself from the power grid when an exception occurs, select a proper overcurrent protection device in compliance with local power distribution regulations.

---

**WARNING**

Do not connect loads between the inverter and the AC switch.

---

The inverter is integrated with a comprehensive residual current detection unit to distinguish fault current from residual current. Upon detecting that the residual current exceeds the threshold, the inverter immediately disconnects from the power grid.

## Cable Connection Precautions

### NOTICE

- The cable outer diameter can be measured using the ruler sticker in the maintenance compartment.
  - Ensure that the cable jacket is in the maintenance compartment.
  - Ensure that the AC output power cable is secured. Failing to do so may cause the solar inverter to malfunction or damage to its terminal block by issues such as overheating.
- 
- The ground point on the enclosure is preferred to connect to the PE cable for the inverter.
  - The PE point in the maintenance compartment is used for connecting to the PE cable included in the multi-core AC power cable.
  - There are two ground points on the chassis shell and you only need either of them.
  - It is recommended that the PE cable of the inverter be connected to a nearby ground point. For a system with multiple inverters connected in parallel, connect the ground points of all inverters to ensure equipotential connections to ground cables.

## Cable Specifications

- If you connect a ground cable to the ground point on the chassis shell, you are advised to use a three-core (L1, L2, and L3) outdoor cable or three single-core outdoor cables.
- If you connect a ground cable to the ground point in the maintenance compartment, you are advised to use a four-core (L1, L2, L3, and PE) outdoor cable.
- You need to prepare the OT or DT terminal that matches the cable.

**Table 5-1** AC power cable specifications

Cable Type	Conductor Cross-Sectional Area	Cable Outer Diameter
Copper-core cable	50–240 mm <sup>2</sup>	<ul style="list-style-type: none"> <li>• Multi-core cable: 24–66 mm</li> <li>• Single-core cable: 14–32 mm</li> </ul>
Copper-clad aluminum cable and aluminum alloy cable	<ul style="list-style-type: none"> <li>• Multi-core cable: 70–240 mm<sup>2</sup></li> <li>• Single-core cable: 70–240 mm<sup>2</sup></li> </ul>	

**NOTE**

- The cable diameter must comply with local cable standards. The factors that affect cable selection include the rated current, cable type, routing mode, ambient temperature, and maximum expected line loss.
- When the MBUS is used for communication, it is recommended that the multi-wire cable be used. The maximum communication distance is 1000 m. If other types of AC power cables are used, contact Huawei technical support.

**Table 5-2** PE cable specifications

Conductor Cross-Sectional Area $S$ of the AC Power Cable (Unit: $\text{mm}^2$ )	Conductor Cross-Sectional Area $S_p$ of the PE Cable (Unit: $\text{mm}^2$ )
$S > 35$	$S_p \geq S/2$
The specifications are valid only if the conductors of the PE cable and AC power cable use the same material. If the materials are different, ensure that the conductor cross-sectional area of the PE cable produces a conductance equivalent to that of the cable specified in this table. The specifications of the PE cable are subject to this table or calculated according to IEC 60364-5-54.	

## Connecting the PE Cable

**Step 1** Secure the PE cable using the ground screw.

**Figure 5-8** Cable connection

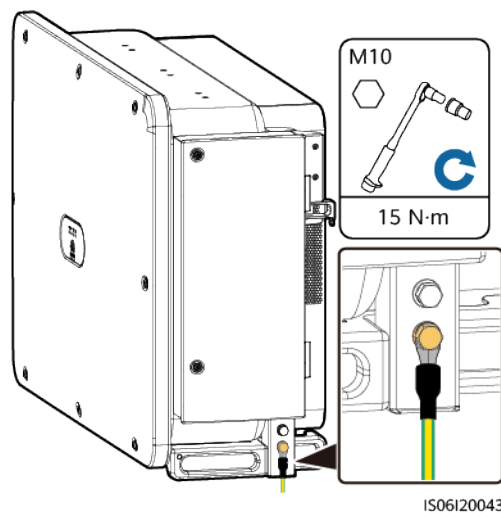

**Step 2** (Optional) Apply silica gel or paint on the ground terminal to protect it against corrosion.

----End

## Connecting the AC Output Power Cable (Multi-core)

**Step 1** Connect the AC cable to the terminal block.

**NOTICE**

Sufficient slack should be provided in the PE cable to ensure that the last cable bearing the force is the PE cable when the AC output power cable bears pulling force due to force majeure.

**Figure 5-9** Cable connection

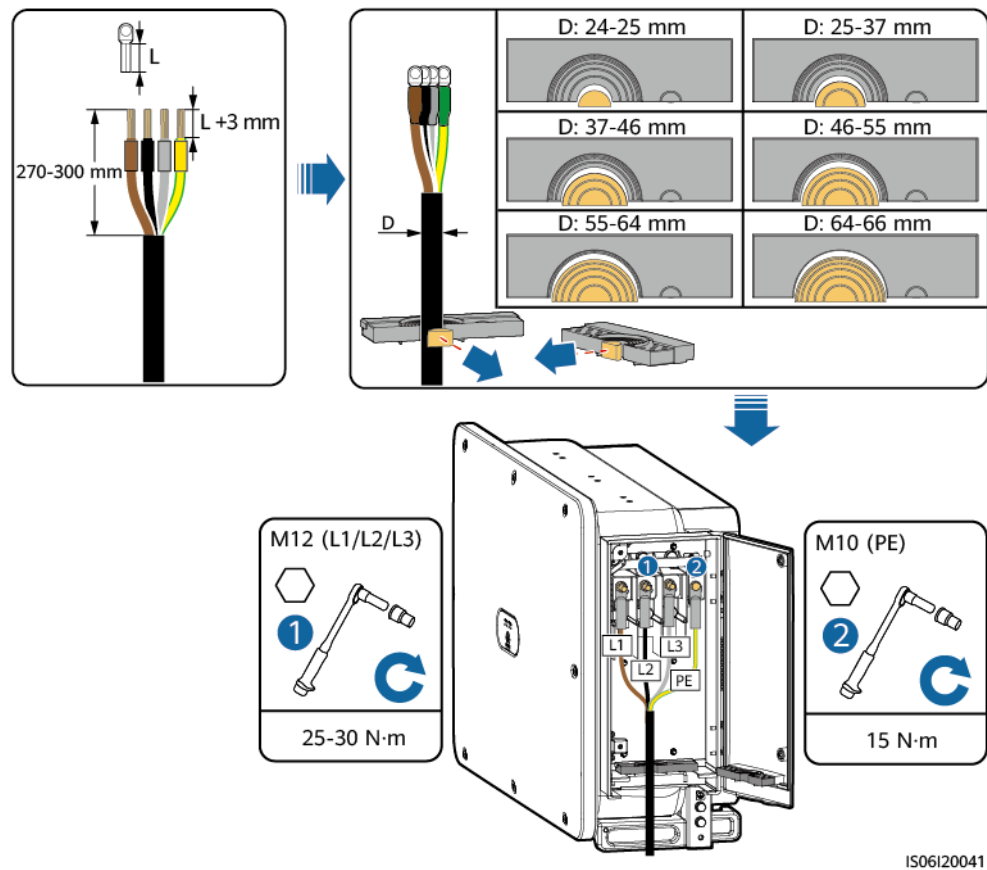

IS06I20041

----End

### Connecting the AC Output Power Cable (Single-core)

**Step 1** Connect the AC cable to the terminal block.

Figure 5-10 Cable connection

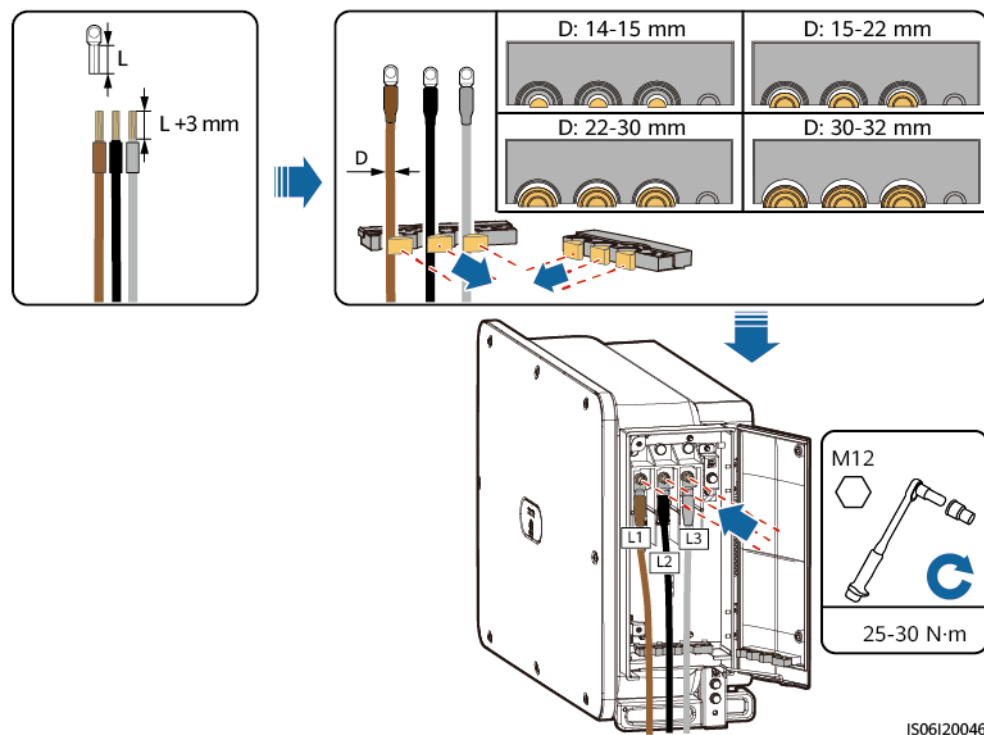

----End

## 5.7 Installing the DC Input Power Cable

### Precautions

#### **⚠ DANGER**

- Before connecting the DC input power cable, ensure that the DC voltage is within the safe range (lower than 60 V DC) and that the three DC switches on the inverter are set to OFF. Failure to do so may result in electric shocks.
- When the inverter operates in grid-tied mode, do not perform maintenance or operations on the DC circuit, such as connecting or disconnecting a PV string or a PV module in the PV string. Failure to do so may cause electric shocks or arcing, which may also cause fire.

#### **⚠ WARNING**

Ensure that the following conditions are met. Otherwise, the inverter may be damaged, or even a fire could happen.

- The open-circuit voltage of each PV string must always be 1500 V DC or lower.
- The polarities of electric connections are correct on the DC input side. The positive and negative terminals of a PV module connect to corresponding positive and negative DC input terminals of the inverter.

**NOTICE**

- Ensure that the PV module output is well insulated to ground.
- The PV strings connecting to the same MPPT circuit should contain the same number of identical PV modules.
- The solar inverter does not support full parallel connection for PV strings (full parallel connection: PV strings connect to one another in parallel outside the solar inverter and then connect to the solar inverter separately).
- During the installation of PV strings and the inverter, the positive or negative terminals of PV strings may be short-circuited to ground if the power cable is not properly installed or routed. In this case, an AC or DC short circuit may occur and damage the inverter. The caused device damage is not covered under any warranty.

### Terminal Description

The inverter provides 18 DC input terminals, which are controlled by its three DC switches. DC SWITCH 1 controls DC input terminals 1–6, DC SWITCH 2 controls DC input terminals 7–12, and DC SWITCH 3 controls DC input terminals 13–18.

**Figure 5-11** DC terminals

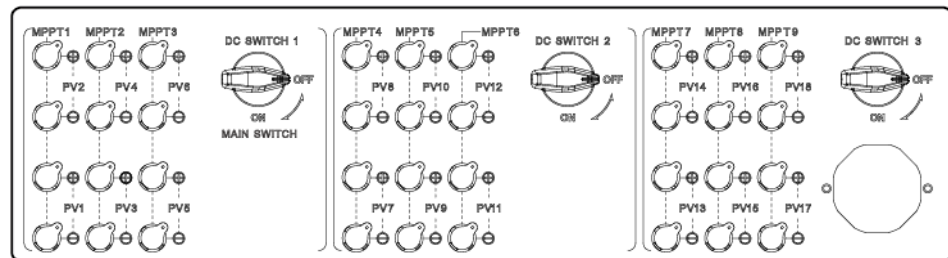

IS06W00062

Requirements for selecting DC input terminals:

1. Evenly distribute the DC input power cables on the DC input terminals controlled by the three DC switches.
2. Maximize the number of connected MPPT circuits.

## Wiring Description of Y-branch Connectors

### NOTICE

- Y-branch connectors can be purchased from Huawei or the manufacturers based on the following recommended models: If the rated current of the fuse of the Y-branch connector is 15 A, the recommended model is 904095944 (Luxshare) or A040959443039 (Comlink); if the rated current of the fuse of the Y-branch connector is 20 A, the recommended model is 904095945 (Luxshare) or A040959453039 (Comlink).
- When connecting cables to recommended Y-branch connectors, ensure that the connectors to be paired match each other and are from the same manufacturer. Otherwise, the contact resistance of the connectors may exceed the allowed value. In this case, the connectors may be heated and oxidized, which may cause faults.
- Ensure that the locking nuts of all connectors are tightened.
- Do not bind more than three fuse enclosures together. Otherwise, the fuses and their enclosures may be damaged due to overheating. It is recommended that a clearance of 10 mm or more be reserved between fuse enclosures. You are advised not to bind the fuse enclosures with other heat emitting conductors.
- Do not place the Y-branch connector harness on the ground. A safe distance must be reserved between the Y-branch connector harness and the ground to avoid impact caused by water on the ground to the harness.
- It is recommended that the Y-branch connectors be connected from the PV string side and tied to the PV trackers.
- The DC input terminals of the solar inverter are prone to damage under stress. When Y-branch connectors are connected to the solar inverter, bind and secure the connectors to minimize stress on the DC input terminals. For details, see [A Securing Y-Branch Connectors](#).

### Wiring rules:

1. The PV+ on the string side must be connected to the PV+ on the SUN2000 side, and the PV- on the string side must be connected to the PV- on the SUN2000 side.
2. Preferentially and evenly connect the Y-branch connectors to the MPPTs controlled by DC SWITCH 1 or DC SWITCH 2.

Number of Y-branch Connector Sets	Recommended MPPT to Be Connected	Number of Y-branch Connector Sets	Recommended MPPT to Be Connected
1	MPPT1	2	MPPT1 and MPPT4
3	MPPT1, MPPT3 and MPPT4	4	MPPT1, MPPT3, MPPT4 and MPPT6

Number of Y-branch Connector Sets	Recommended MPPT to Be Connected	Number of Y-branch Connector Sets	Recommended MPPT to Be Connected
5	MPPT1, MPPT2, MPPT3, MPPT4, and MPPT5	6	MPPT1, MPPT2, MPPT3, MPPT4, MPPT5, and MPPT6
7	MPPT1, MPPT2, MPPT3, MPPT4, MPPT5, MPPT6, and MPPT7	8	MPPT1, MPPT2, MPPT3, MPPT4, MPPT5, MPPT6, MPPT7, and MPPT8
9	MPPT1, MPPT2, MPPT3, MPPT4, MPPT5, MPPT6, MPPT7, MPPT8, and MPPT9	N/A	N/A

**Figure 5-12** Y-branch Connector Solution

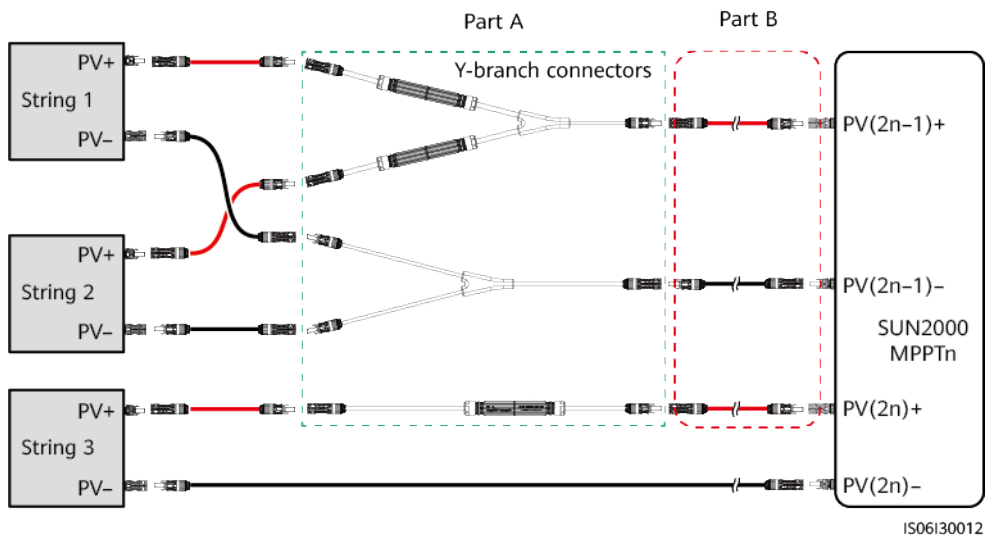

Scenario	Model of Y-branch Connector (Part A)	Connection Description
Connecting Y-branch connectors to the PV strings (recommended)	All models	Use the DC terminals delivered with the SUN2000s to connect part B to the SUN2000s.

Scenario	Model of Y-branch Connector (Part A)	Connection Description
Connecting Y-branch connectors to the SUN2000	Models recommended by Huawei	Part A can be directly connected to the SUN2000, and part B is not needed.
	Other models	To ensure that the terminals of part A match the DC terminals of the SUN2000, part B is needed to connect part A to the SUN2000. Use the DC terminals delivered with the SUN2000 to connect part B to the SUN2000.

## Cable Specifications

Cable Type	Conductor Cross-sectional Area (Unit: mm <sup>2</sup> )	Cable Outer Diameter (Unit: mm)
PV cable that meets the 1500 V standard	4-6	4.7-6.4

### NOTICE

Cables with high rigidity, such as armored cables, are not recommended, because poor contact may be caused by the bending of cables.

## Procedure

### NOTICE

- Use the MC4 EVO2 PV connectors delivered with the inverter. If the PV connectors are lost or damaged, purchase the connectors of the same model. The device damage caused by incompatible PV connectors is beyond the warranty scope.
- For models of the crimping tool and removal wrench, use the recommended model or contact your Staubli dealer.

**Step 1** Install the DC input power cable.

**NOTICE**

- The DC voltage measurement range of the multimeter must be at least 1500 V.
- If the voltage is a negative value, the DC input polarity is incorrect and needs correction.
- If the voltage is greater than 1500 V, too many PV modules configured to the same string. Remove some PV modules.
- Connect the PV string connector to the inverter connector, and then pull back the PV string connector along the axial direction to check whether the connectors are securely connected.
- The connector must be securely connected. Damages caused by improper connection are not covered under the warranty.

**Figure 5-13** Cable connection

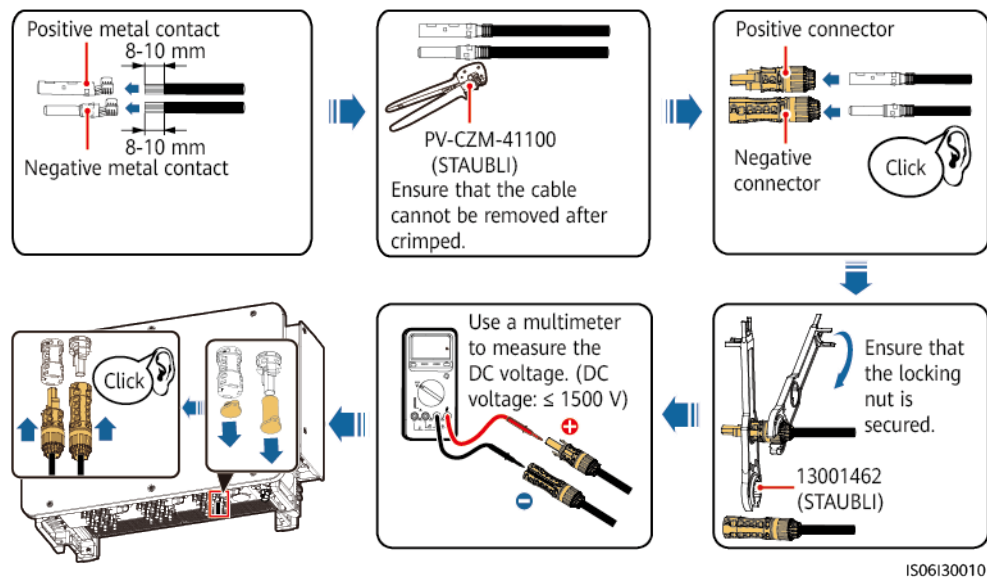

**Figure 5-14** Connector connection

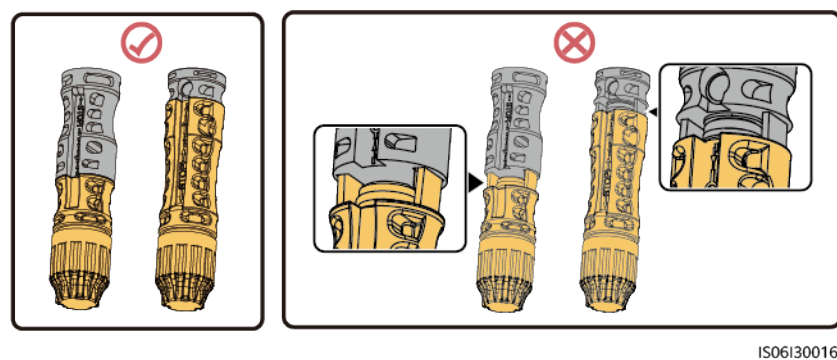

**NOTICE**

During DC input power cabling, leave at least 50 mm of slack. The axial tension on PV connectors must not exceed 80 N. Radial stress or torque must not be generated on PV connectors.

**Figure 5-15** DC input power cabling requirement

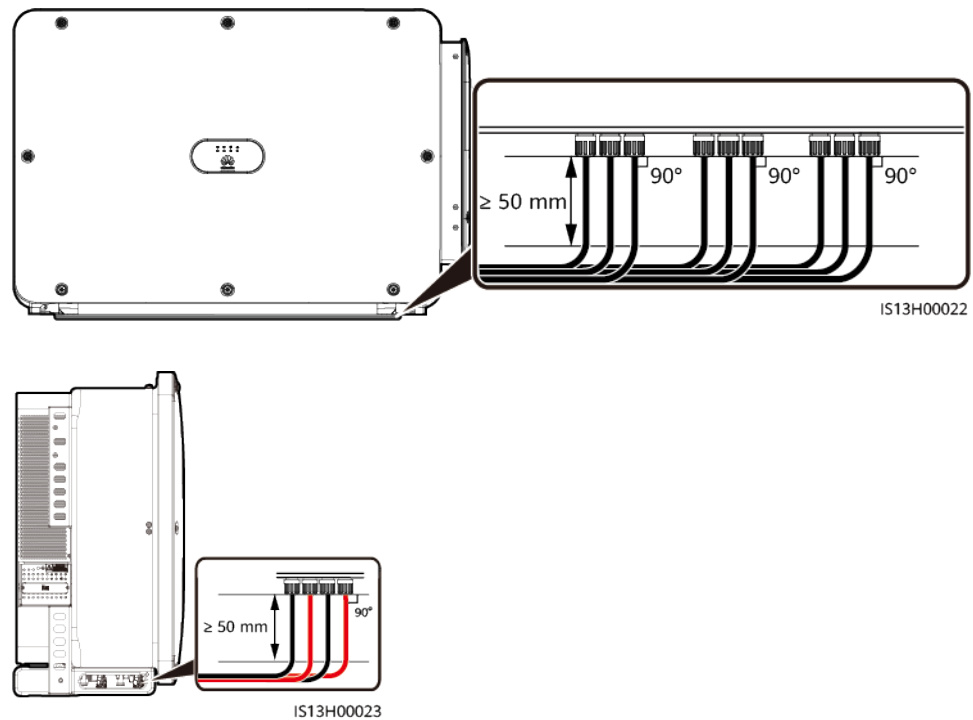

----End

## 5.8 Installing the Communications Cable

### Precautions

When routing communications cables, separate communications cables from power cables to prevent communication from being affected.

## Pin Definitions of Communications Ports

Figure 5-16 Communications ports

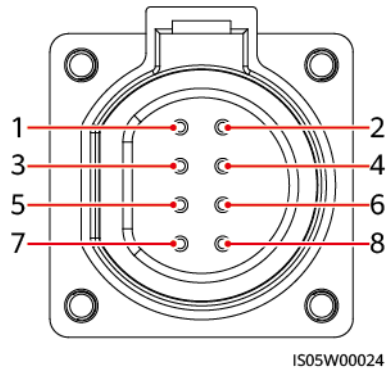

Port	Pin	Definition	Pin	Definition	Description
RS485-1	1	RS485A IN, RS485 differential signal+	2	RS485A OUT, RS485 differential signal+	Used for cascading inverters or connecting to devices such as the SmartLogger.
	3	RS485B IN, RS485 differential signal-	4	RS485B OUT, RS485 differential signal-	
PE	5	PE, shielding ground	6	PE, shielding ground	-
RS485-2	7	RS485A, RS485 differential signal+	8	RS485B, RS485 differential signal-	Used for connecting to RS485 slave devices.

## Procedure

**Step 1** Install the communications cable.

Figure 5-17 Cable connection (4–8 mm four-hole rubber plug)

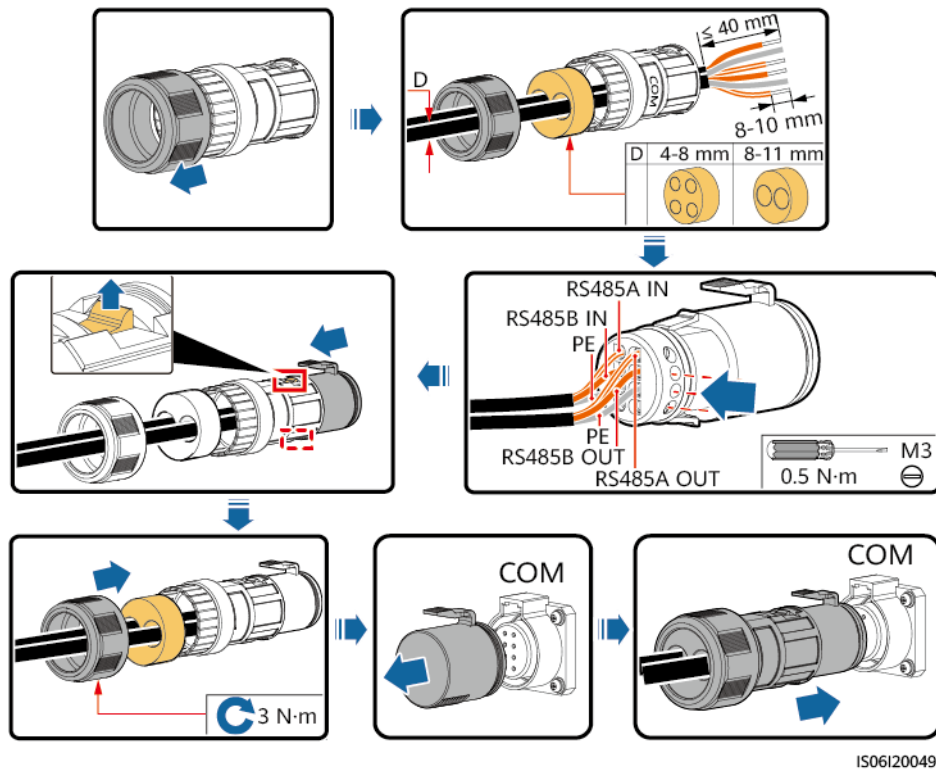

**NOTICE**

Block unused cable holes using plugs and tighten cable glands.

**Figure 5-18** Cable connection (4–8 mm two-hole rubber plug)

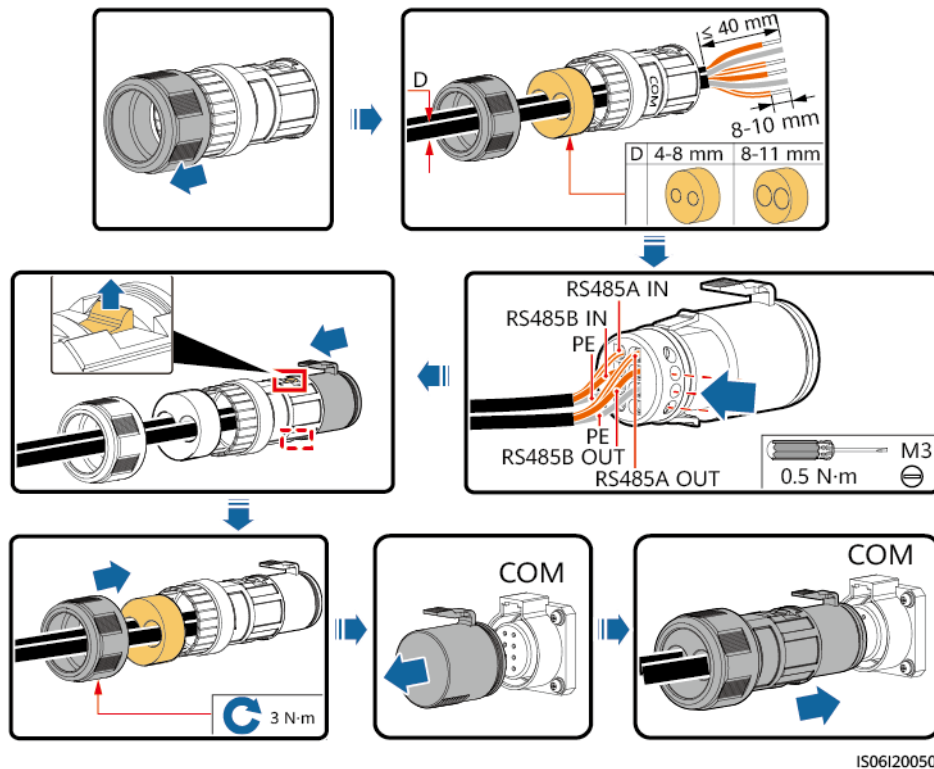

**NOTICE**

- If three communications cables are to be connected, use the three-hole rubber plug that is bound in the maintenance compartment.
- Block unused cable holes using plugs and tighten cable glands.

----End

## 5.9 Closing the Maintenance Compartment Door

### Procedure

- Step 1** Adjust the support bar, close the maintenance compartment door and tighten the two screws on the door.

**Figure 5-19** Closing the door

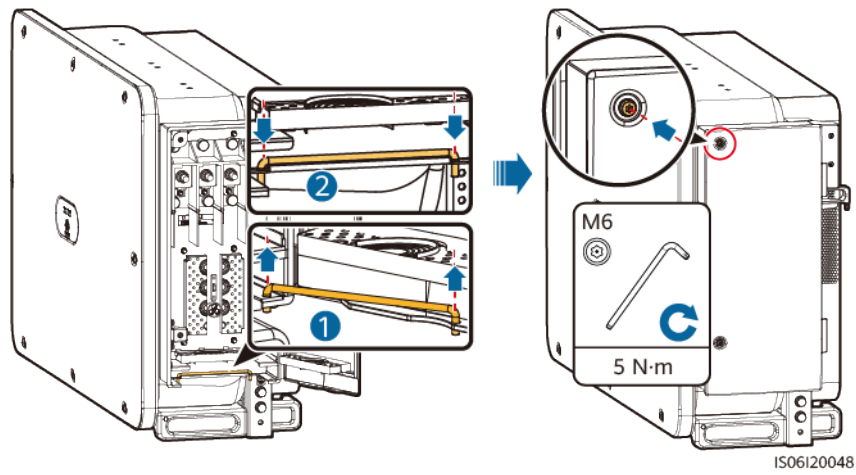

----End

# 6 System Commissioning

---

## 6.1 Check Before Power-on

1. The inverter is installed correctly and securely.
2. Check that the DC switches and downstream AC output switch are OFF.
3. Check that all ground cables are connected securely and reliably.
4. All AC output power cables are connected correctly and securely, without open circuits or short circuits.
5. All DC input power cables are connected correctly and securely, without open circuits or short circuits.
6. The communications cable is connected correctly and securely.
7. Check that the maintenance compartment interior is clean and tidy, without foreign matter.
8. The maintenance compartment door is closed and the door screws are tightened.
9. Idle DC input terminals are sealed.
10. Idle USB ports are plugged with waterproof plugs.

## 6.2 System Power-On

### Precautions

---

**NOTICE**

- Before turning on the AC switch between the inverter and the power grid, check that the AC voltage is within the specified range using a multimeter.
  - If the solar inverter has not been running for more than half a year after being mounted, it must be checked and tested by professionals before being put into operation.
-

## Procedure

- Step 1** (Optional) Remove the screws that secure DC SWITCH 1, DC SWITCH 2, and DC SWITCH 3, and keep the screws properly for the power-off maintenance later.
- Step 2** Turn on the AC switch between the inverter and the grid.

---

**NOTICE**

If you perform **Step 3** before **Step 2**, the inverter reports a fault about abnormal shutdown. The inverter can start normally after the fault is automatically cleared.

---

- Step 3** Set DC SWITCH 1 (MAIN SWITCH) at the bottom of the SUN2000 chassis to ON.
- Step 4** Check the status of LED 1. If it is steady green, set DC SWITCH 2 and DC SWITCH 3 to ON.

----End

# 7 Man-Machine Interactions

---

## 7.1 Operations with the App

### 7.1.1 App Introduction

#### Functions

- The FusionSolar app is recommended when the SUN2000 is connected to the FusionSolar hosting cloud. The SUN2000 app is recommended when the SUN2000 is connected to other management systems.
- The SUN2000 or FusionSolar app (app for short) is a mobile phone app that communicates with the SUN2000 over a WLAN/Bluetooth module or a USB data cable to allow for querying alarms, setting parameters, and performing routine maintenance as an easy-to-use maintenance platform.

#### Connection Mode

After the DC or AC side of the SUN2000 is powered on, you can connect the app to it through a WLAN module, a Bluetooth module or a USB data cable.

---

#### NOTICE

- Over a WLAN module: The USB-Adapter2000-C WLAN module is supported.
  - Over a Bluetooth module: The USB-Adapter2000-B Bluetooth module is supported.
  - Over a USB data cable: The USB 2.0 port is supported. Use the USB data cable delivered with the mobile phone.
  - Mobile phone operating system: Android 4.0 or later.
  - Recommended phone brands: Huawei and Samsung.
-

**Figure 7-1** Connection over a WLAN module or a Bluetooth module

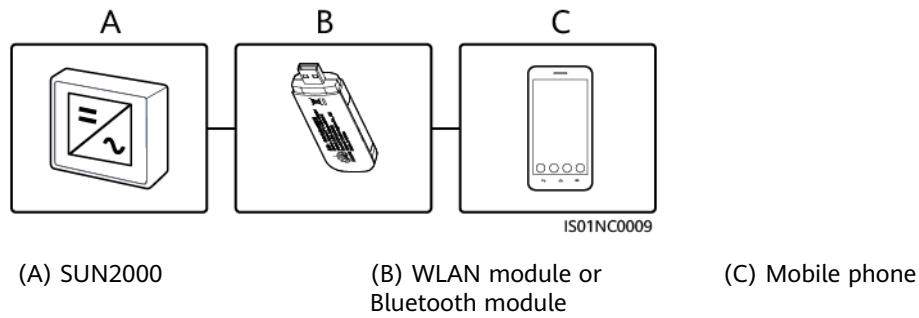

**Figure 7-2** Connection over a USB data cable

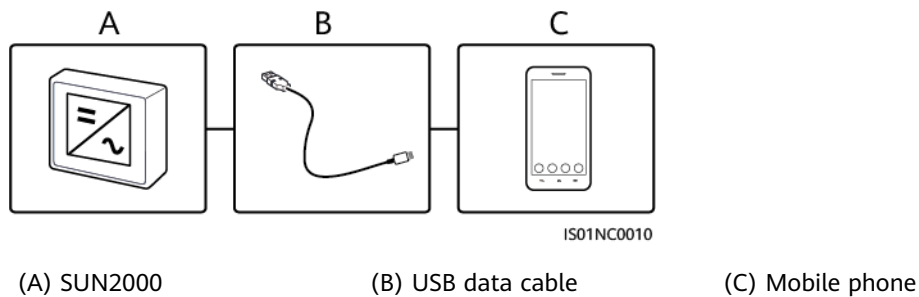

## Disclaimer

### NOTICE

- The configurable parameters of the SUN2000 vary with the device model and grid code.
- If you change the grid code, some parameters may be restored to factory defaults. After the grid code is changed, check whether the previously set parameters are affected.
- Delivering a reset, factory reset, shutdown, or upgrade command to the solar inverters may cause power grid connection failure, which affects the energy yield.
- Only professionals are allowed to set the grid parameters, protection parameters, feature parameters, and power adjustment parameters of the solar inverters. If the grid parameters, protection parameters, and feature parameters are incorrectly set, the solar inverters may not connect to the power grid. If the power adjustment parameters are incorrectly set, the solar inverters may not connect to the power grid as required. In these cases, the energy yield will be affected.
- The parameter names, value ranges, and default values are subject to change.

## 7.1.2 Downloading and Installing the App

- FusionSolar app: Scan the QR code and download the latest installation package.

- SUN2000 app: Log in to Huawei AppGallery (<https://appstore.huawei.com>), search for **SUN2000**, and download the app installation package. You can also scan the QR code (<https://appgallery.cloud.huawei.com/appdl/C10279542>) to download the installation package.

QR code:

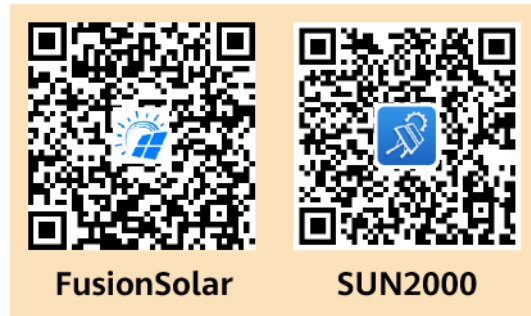

### 7.1.3 Logging In to the App

#### Prerequisites

- The DC or AC side of the SUN2000 has been energized.
- Connection over a WLAN module or a Bluetooth module:
  - a. The WLAN module or Bluetooth module is connected to the **USB** port at the bottom of the SUN2000.
  - b. The WLAN or Bluetooth function is enabled.
  - c. Keep the mobile phone within 5 m from the SUN2000. Otherwise, the communication between them would be affected.
- Connection over a USB cable:
  - a. The USB data cable is connected from the USB port at the bottom of the SUN2000 to the port on the mobile phone.
  - b. If the USB data cable is successfully connected, the message **Connected to USB Accessory** will pop up on the phone. Otherwise, the cable is not connected.

#### Procedure

1. Run the app and select a connection mode.

 **NOTE**

- The screenshots in this document correspond to the SUN2000 app 3.2.00.003 (Android) and FusionSolar app 2.5.7 (Android).
  - When the WLAN connection is used, scan the QR code of the WLAN module to access the login screen.
  - When the WLAN connection is used, the initial name of the WLAN hotspot is **Adapter-WLAN module SN**, and the initial password is **Changeme**. Use the initial password upon first power-on and change it immediately after login. To ensure account security, change the password periodically and keep the new password in mind. Not changing the initial password may cause password disclosure. A password left unchanged for a long period of time may be stolen or cracked. If a password is lost, devices cannot be accessed. In these cases, the user is liable for any loss caused to the PV plant.
  - When the Bluetooth connection is used, the connected Bluetooth device is named after **last 8 digits of the SN barcode+HWAPP**.
  - After you select **Use by default for this USB accessory**, a message that asks you to confirm the USB access will not appear if you log in to the app again without removing the USB data cable.
- a. (Scenario in which the SUN2000 is connected to the FusionSolar hosting cloud) Run the FusionSolar app and access the **Device Commissioning** screen.

Figure 7-3 Selecting a connection mode (with network access)

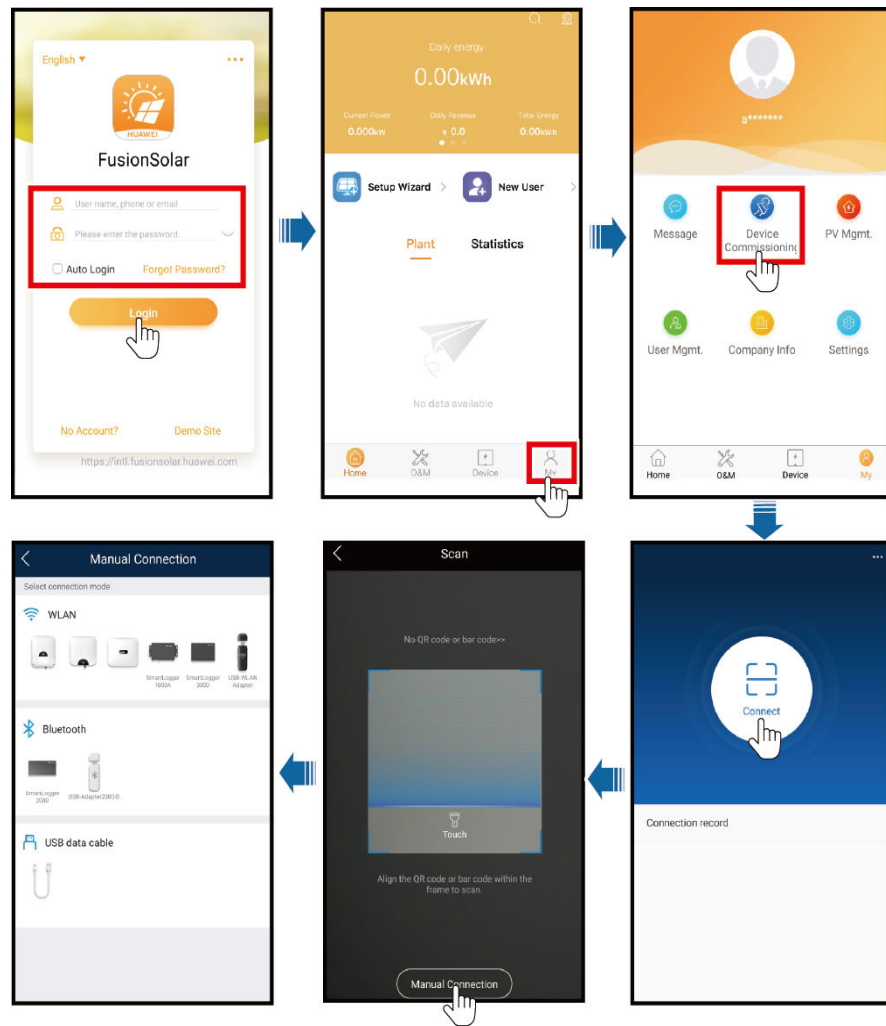
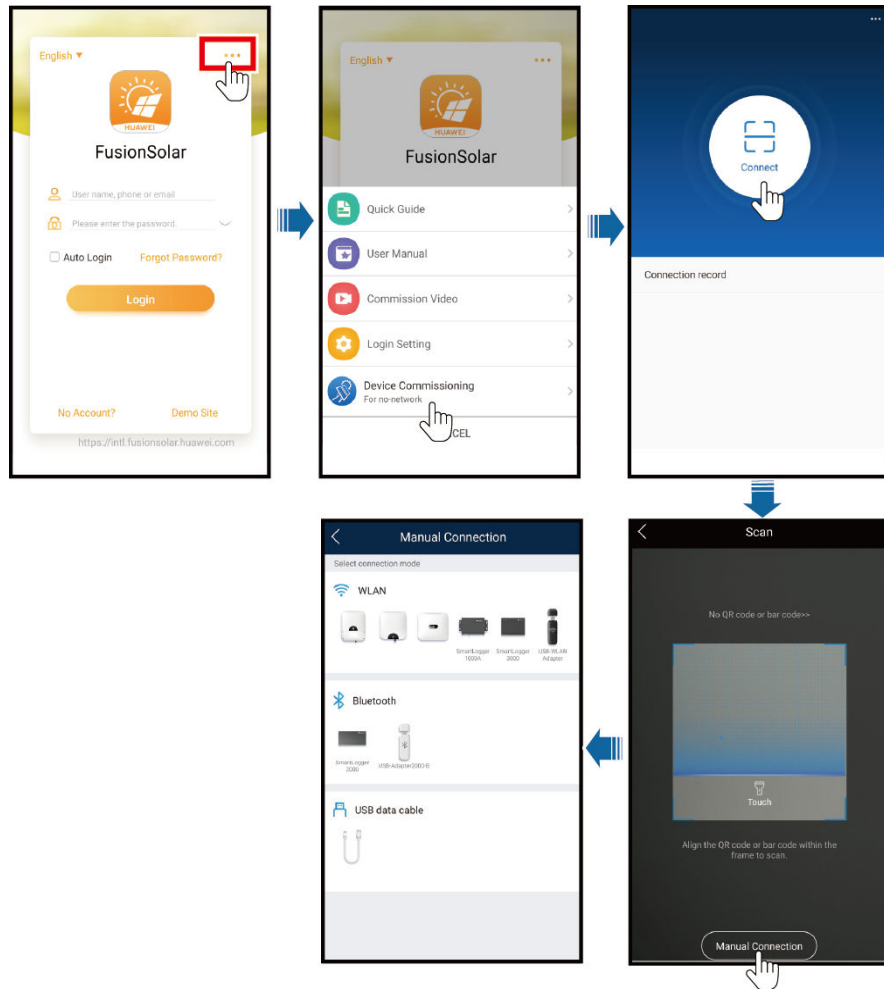
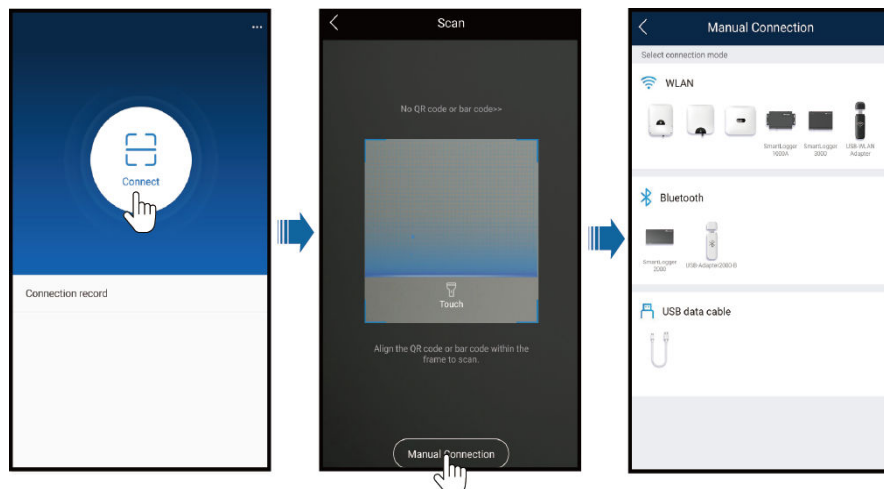

Figure 7-4 Selecting a connection mode (without network access)



- b. (Scenario in which the SUN2000 is connected to other management systems) Run the SUN2000 app and access the operation screen.

Figure 7-5 Selecting a connection method



- 2. Select a login user and enter the login password to access the quick settings screen or the main menu screen.

### NOTICE

- The login password is the same as that for the SUN2000 connected to the app and is used only when the SUN2000 connects to the app.
- The initial passwords for **Common User**, **Advanced User**, and **Special User** are all **00000a**.
- Use the initial password upon first power-on and change it immediately after login. To ensure account security, change the password periodically and keep the new password in mind. Not changing the initial password may cause password disclosure. A password left unchanged for a long period of time may be stolen or cracked. If a password is lost, devices cannot be accessed. In these cases, the user is liable for any loss caused to the PV plant.
- During the login, if five consecutive invalid password entries are made (the interval between two consecutive entries is less than 2 minutes), the account will be locked for 10 minutes. The password should consist of six characters.
- If you log in to the app after the device connects to the app for the first time or factory defaults are restored, the quick settings screen will be displayed. Set basic parameters as prompted. If you do not set basic parameters for the inverter on the quick settings screen, the screen is still displayed when you log in to the app next time.
- To set SUN2000 basic parameters on the quick settings screen, switch to **Advanced User**. If you log in as **Common User** or **Special User**, enter the password of the advanced user to access the **Quick Settings** screen.

Figure 7-6 Login

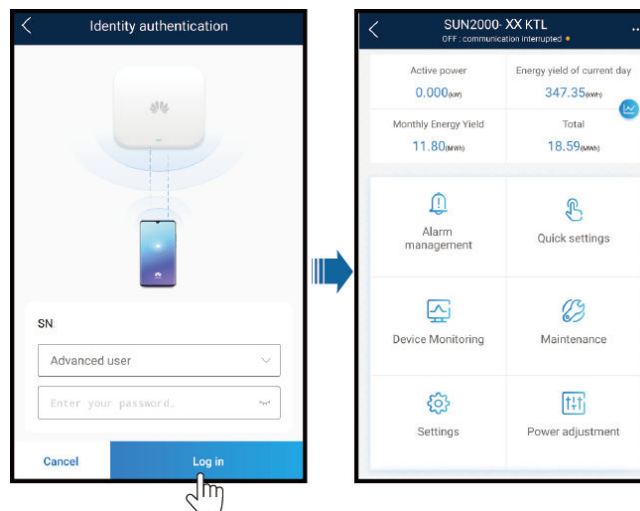

## 7.1.4 Operations Related to the Advanced User

If you log in to the app as **Advanced User**, you can set grid parameters, protection parameters, and feature parameters for the SUN2000.

### 7.1.4.1 Setting Grid Parameters

#### Procedure

- Step 1** Choose **Function Menu > Settings > Grid Parameters** to access the parameters setting screen.

**Figure 7-7** Grid parameters (advanced user)

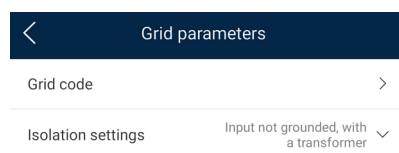

----End

#### Parameters

No.	Parameter	Description
1	Grid Code	Set this parameter based on the grid code of the country or region where the inverter is used and the inverter application scenario.
2	Isolation settings	Set the working mode of the inverter based on the grounding status at DC side and the connection to the power grid.

### 7.1.4.2 Setting Protection Parameters

#### Procedure

- Step 1** Choose **Function Menu > Settings > Protect Parameters** to go to the parameter setting screen.

**Figure 7-8** Protection parameters (advanced user)



----End

#### Parameter

No.	Parameter	Description
1	Insulation resistance protection threshold (MΩ)	To ensure device safety, the inverter detects the insulation resistance of the input side with respect to ground when it starts a self-check. If the detected value is less than the preset value, the inverter does not connect to the grid.

### 7.1.4.3 Setting Feature Parameters

#### Procedure

**Step 1** Choose **Function Menu > Settings > Feature Parameters** to access the settings screen.

**Figure 7-9** Feature parameters (advanced user)

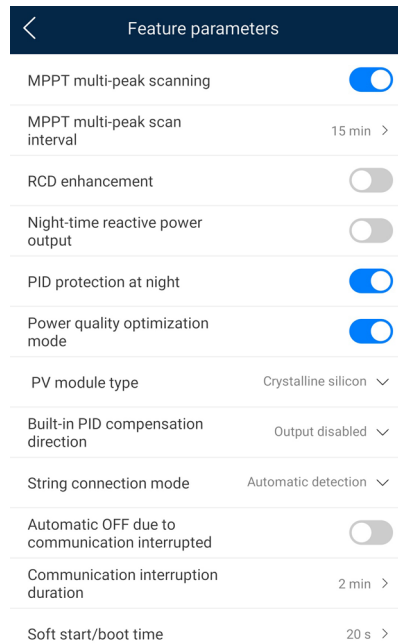

----End

#### Parameters

No.	Parameter	Description	Remarks
1	MPPT multi-peak scanning	When the inverter is used in scenarios where PV strings are greatly shaded, set this parameter to <b>Enable</b> , and then the inverter will perform MPPT scanning at regular intervals to locate the maximum power.	-
2	MPPT multi-peak scan interval (min)	Specifies the MPPT scanning interval.	This parameter is displayed when <b>MPPT multi-peak scanning</b> is set to <b>Enable</b> .

No.	Parameter	Description	Remarks
3	RCD enhancement	RCD refers to the residual current of the inverter to the ground. To ensure device and personal safety, RCD should be limited to the specified value in the standard. If an AC switch with a residual current detection function is installed outside the inverter, this function should be enabled to reduce the residual current generated when the inverter is running, thereby preventing the AC switch from misoperations.	-
4	Night-time reactive power output	In some specific application scenarios, a power grid company requires that the inverter can perform reactive power compensation at night to ensure that the power factor of the local power grid meets requirements.	This parameter is displayed when <b>Isolation settings</b> is set to <b>Input ungrounded, with TF</b> .
5	PID protection at night	When the inverter outputs reactive power at night and this parameter is set to <b>Enable</b> , the inverter will shut down automatically if it detects abnormal status of the PID compensation.	-
6	Power quality optimization mode	If this parameter is set to <b>Enable</b> , the inverter output current harmonics will be optimized.	-

No.	Parameter	Description	Remarks
7	PV module type	This parameter is used to set different types of PV modules and the shutdown time of the concentration PV module. If the concentration PV modules are shaded, the power drops drastically to 0 and the inverter shuts down. The energy yield would be affected since it takes too long for the power to resume and inverter to restart. The parameter does not need to be set for crystalline silicon and filmy PV modules.	<ul style="list-style-type: none"> <li>● If this parameter is set to <b>Crystalline silicon</b> or <b>Film</b>, the inverter automatically detects the power of PV modules when they are shaded and shuts down if the power is too low.</li> <li>● When concentration PV modules are used: <ul style="list-style-type: none"> <li>– If this parameter is set to <b>CPV 1</b>, the inverter can quickly restart in 60 minutes if the input power of PV modules drops drastically due to shading.</li> <li>– If this parameter is set to <b>CPV 2</b>, the inverter can quickly restart in 10 minutes if the input power of PV modules drops drastically due to shading.</li> </ul> </li> </ul>
8	Built-in PID compensation direction	When the external PID module compensates the PID voltage for the PV system, set <b>Built-in PID compensation direction</b> to the actual compensation direction of the PID module so that the inverter can output reactive power at night.	-
9	String connection mode	Specifies the connection mode of PV strings.	<ul style="list-style-type: none"> <li>● When PV strings connect to the inverter separately (All PV strings separated), there is no need to set this parameter. The inverter can automatically detect the connection mode of the PV strings.</li> <li>● When PV strings connect to one another in parallel outside the inverter and then connect to it independently (All PV strings connected), set this parameter to <b>All PV strings connected</b>.</li> </ul>

No.	Parameter	Description	Remarks
10	Automatic OFF due to communication interrupted	The standards of certain countries and regions require that the inverter must shut down after the communication is interrupted for a certain time.	If <b>Automatic OFF due to communication interrupted</b> is set to <b>Enable</b> and the inverter communication is interrupted for a specified time (set by <b>Communication interruption duration</b> ), the inverter will automatically shut down.
11	Automatic ON due to communication resumed	If this parameter is set to <b>Enable</b> , the inverter automatically starts after communication recovers. If this parameter is set to <b>Disable</b> , the inverter needs to be started manually after communication recovers.	This parameter is displayed when <b>Automatic OFF due to communication interrupted</b> is set to <b>Enable</b> .
12	Communication interruption duration (min)	Specifies the duration for determining communication interruption. Used for automatic shutdown for protection in case of communication interruption.	-
13	Soft start/boot time (s)	Specifies the duration for the power to gradually increase when the inverter starts.	-
14	Shutdown gradient (%/s)	Specifies the power change speed when the inverter shuts down.	-
15	Night-time hibernation	The inverter monitors PV strings at night. If this parameter is set to <b>Enable</b> , the monitoring function of the inverter will hibernate at night to reduce power consumption.	-
16	MBUS communication	For inverters that support RS485 communication and MBUS communication, you are advised to set this parameter to <b>Disable</b> to reduce power consumption.	-
17	Delay upgrade	This parameter is mainly used in the upgrade scenarios where the PV power supply is disconnected at night due to no sunlight or unstable at dawn or dusk due to poor sunlight.	After the inverter starts to upgrade, if <b>Delay upgrade</b> is set to <b>Enable</b> , the upgrade package is loaded first. After the PV power supply recovers and the activation conditions are met, the inverter automatically activates the upgrade.

No.	Parameter	Description	Remarks
18	RS485-2 communication	If this parameter is set to <b>Enable</b> , the RS485-2 port can be used. If the port is not used, you are advised to set this parameter to <b>Disable</b> to reduce power consumption.	-
19	Duration for determining short-time grid disconnection (ms)	The standards of certain countries and regions require that the inverter should not disconnect from the power grid if the power grid experiences a short-time failure. After the fault is rectified, the inverter output power needs to be quickly restored.	-

## 7.1.5 Operations Related to the Special User

If you log in to the app as **Special User**, you can set grid parameters, protection parameters, feature parameters, and power adjustment parameters for the SUN2000.

### 7.1.5.1 Setting Grid Parameters

#### Procedure

- Step 1** Choose **Function Menu > Settings > Grid Parameters** to access the parameters setting screen.

**Figure 7-10** Power grid parameters (special user)

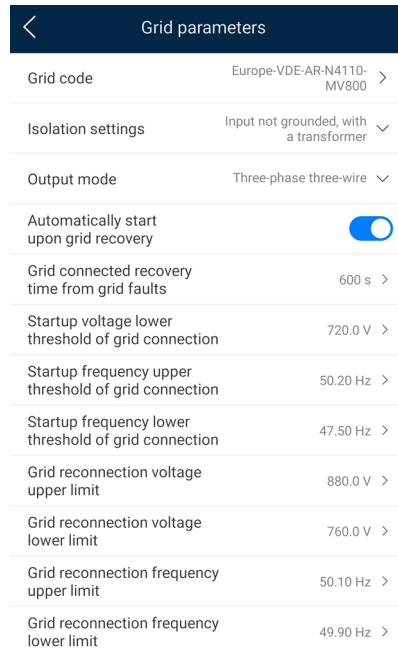

----End

## Parameters

No.	Parameter	Description
1	Grid Code	Set this parameter based on the grid code of the country or region where the inverter is used and the inverter application scenario.
2	Isolation settings	Set the working mode of the inverter based on the grounding status at DC side and the connection to the power grid.
3	Output mode	Specifies whether the inverter output has a neutral wire based on the application scenario.
4	Automatically start upon grid recovery	Specifies whether to allow the inverter to automatically start after the power grid recovers.
5	Grid connected recovery time from grid faults (s)	Specifies the time after which the inverter begins restarting after the power grid recovers.
6	Startup voltage lower threshold of grid connection (V)	According to the standards of certain countries and regions, after the inverter is powered on for the first time for grid connection, if the power grid voltage is lower than <b>Startup voltage lower threshold of grid connection</b> , the inverter is not allowed to connect to the grid.

No.	Parameter	Description
7	Startup frequency upper threshold of grid connection (Hz)	According to the standards of certain countries and regions, after the inverter is powered on for the first time for grid connection, if the power grid voltage is higher than <b>Startup frequency upper threshold of grid connection</b> , the inverter is not allowed to connect to the grid.
8	Startup frequency lower threshold of grid connection (Hz)	According to the standards of certain countries and regions, after the inverter is powered on for the first time for grid connection, if the power grid voltage is lower than <b>Startup frequency lower threshold of grid connection</b> , the inverter is not allowed to connect to the grid.
9	Grid reconnection voltage upper limit (V)	The standards of certain countries and regions require that after the inverter shuts down for protection due to a fault, if the power grid voltage is higher than <b>Grid reconnection voltage upper limit</b> , the inverter is not allowed to reconnect to the grid.
10	Grid reconnection voltage lower limit (V)	The standards of certain countries and regions require that after the inverter shuts down for protection due to a fault, if the power grid voltage is lower than <b>Grid reconnection voltage lower limit</b> , the inverter is not allowed to reconnect to the grid.
11	Grid reconnection frequency upper limit (Hz)	The standards of certain countries and regions require that after the inverter shuts down for protection due to a fault, if the power grid frequency is higher than <b>Grid reconnection frequency upper limit</b> , the inverter is not allowed to reconnect to the grid.
12	Grid reconnection frequency lower limit (Hz)	The standards of certain countries and regions require that after the inverter shuts down for protection due to a fault, if the power grid frequency is lower than <b>Grid reconnection frequency lower limit</b> , the inverter is not allowed to reconnect to the grid.
13	Reactive power compensation (cos $\phi$ -P) trigger voltage (%)	Specifies the voltage threshold for triggering reactive power compensation based on the cos $\phi$ -P curve.
14	Reactive power compensation (cos $\phi$ -P) exit voltage (%)	Specifies the voltage threshold for exiting reactive power compensation based on the cos $\phi$ -P curve.

## 7.1.5.2 Setting Protection Parameters

### Procedure

- Step 1** Choose **Function Menu > Settings > Protect Parameters** to go to the parameter setting screen.

**Figure 7-11** Protection parameters (special user)

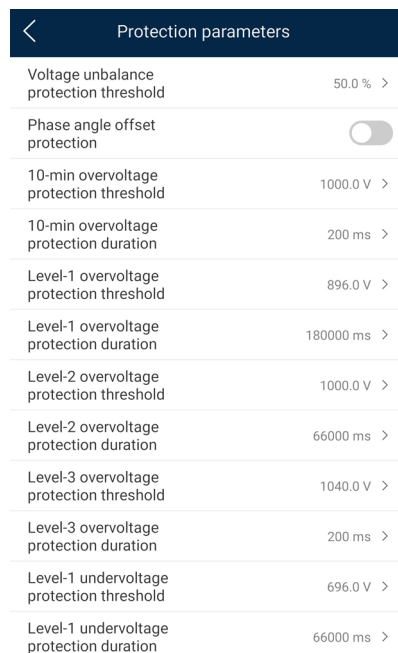

Parameter	Value
Voltage unbalance protection threshold	50.0 %
Phase angle offset protection	<input type="checkbox"/>
10-min overvoltage protection threshold	1000.0 V
10-min overvoltage protection duration	200 ms
Level-1 overvoltage protection threshold	896.0 V
Level-1 overvoltage protection duration	180000 ms
Level-2 overvoltage protection threshold	1000.0 V
Level-2 overvoltage protection duration	66000 ms
Level-3 overvoltage protection threshold	1040.0 V
Level-3 overvoltage protection duration	200 ms
Level-1 undervoltage protection threshold	696.0 V
Level-1 undervoltage protection duration	66000 ms

----End

### Parameters

No.	Parameter	Description
1	Voltage unbalance protection threshold (%)	Specifies the inverter protection threshold when the power grid voltage is unbalanced.
2	Phase angle offset protection	The standards of certain countries and regions require that the inverter needs to be protected when the phase angle offset of the power grid three phases exceeds a certain value.
3	10-min overvoltage protection threshold (V)	Specifies the 10-minute overvoltage protection threshold.
4	10-min overvoltage protection duration (ms)	Specifies the 10-minute overvoltage protection duration.
5	Level-N overvoltage protection threshold (V)	Specifies the level-N grid overvoltage protection threshold.
6	Level-N overvoltage protection duration (ms)	Specifies the level-N grid overvoltage protection duration.

No.	Parameter	Description
7	Level-N undervoltage protection threshold (V)	Specifies the level-N grid undervoltage protection threshold.
8	Level-N undervoltage protection duration (ms)	Specifies the level-N grid undervoltage protection duration.
9	Level-N overfrequency protection threshold (Hz)	Specifies the level-N grid overfrequency protection threshold.
10	Level-N overfrequency protection duration (ms)	Specifies the level-N grid overfrequency protection duration.
11	Level-N underfrequency protection threshold (Hz)	Specifies the level-N grid underfrequency protection threshold.
12	Level-N underfrequency protection duration (ms)	Specifies the level-N grid underfrequency protection duration.

### 7.1.5.3 Setting Feature Parameters

#### Procedure

- Step 1** Choose **Function Menu > Settings > Feature Parameters** to access the settings screen.

**Figure 7-12** Feature parameters (special user)

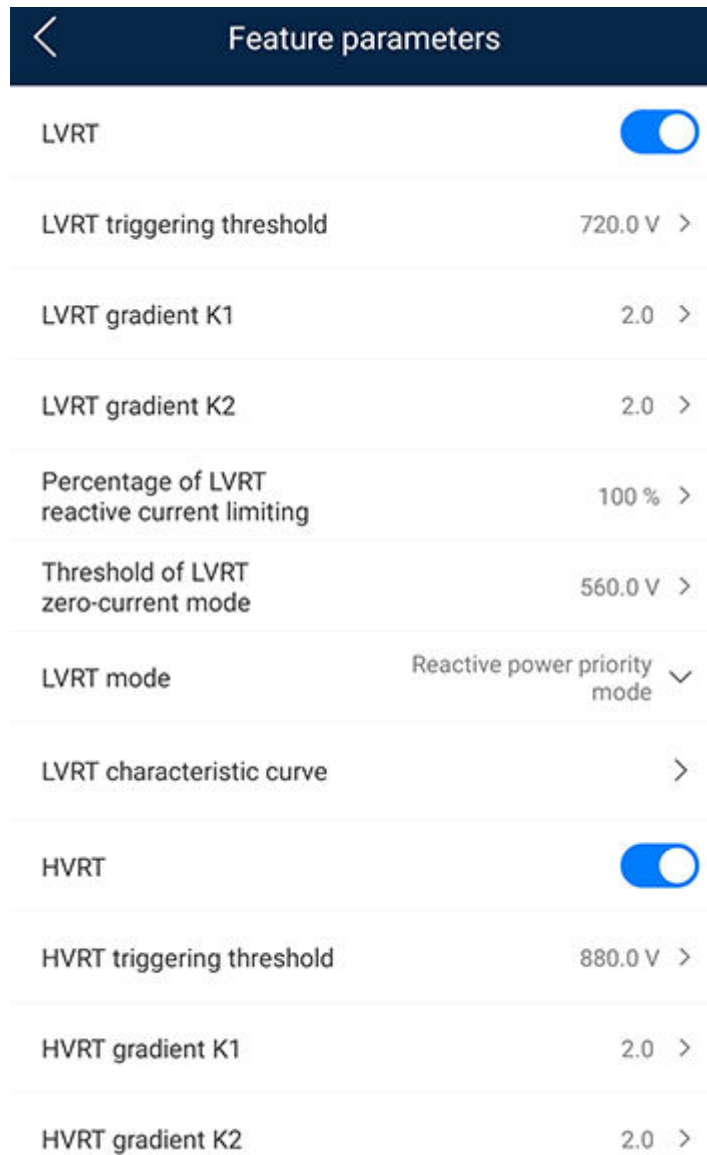

----End

### Parameters

No.	Parameter	Description	Remarks
1	LVRT	LVRT is short for low voltage ride-through. When the grid voltage is abnormally low for a short time, the inverter cannot disconnect from the power grid immediately and has to work for some time.	-
2	Threshold for triggering LVRT (V)	Specifies the threshold for triggering LVRT. The threshold settings should meet the local grid standard.	This parameter is displayed when <b>LVRT</b> is set to <b>Enable</b> .

No.	Parameter	Description	Remarks
3	LVRT gradient K1	<p>During LVRT, the solar inverter needs to generate positive-sequence reactive power to support the power grid. This parameter is used to set the positive-sequence reactive power generated by the solar inverter.</p> <p>For example, if you set <b>LVRT gradient K1</b> to <b>2</b>, the positive-sequence reactive current generated by the solar inverter is 20% of the rated current when the AC voltage decreases by 10% during LVRT.</p>	
4	LVRT gradient K2	<p>During LVRT, the solar inverter needs to generate negative-sequence reactive power to support the power grid. This parameter is used to set the negative-sequence reactive power generated by the solar inverter.</p> <p>For example, if you set <b>LVRT gradient K2</b> to <b>2</b>, the negative-sequence reactive current generated by the solar inverter is 20% of the rated current when the AC voltage decreases by 10% during LVRT.</p>	
5	Percentage of LVRT reactive current limiting	<p>During LVRT, the solar inverter needs to limit the reactive current.</p> <p>For example, if you set <b>Percentage of LVRT reactive current limiting</b> to <b>50</b>, the reactive current upper limit of the solar inverter is 50% of the rated current during LVRT.</p>	
6	Threshold of LVRT zero-current mode	<p>When <b>Zero current due to power grid fault</b> is enabled, if the power grid voltage is less than the value of <b>Threshold of LVRT zero-current mode</b> during LVRT, the zero current mode is used. Otherwise, the mode configured in <b>LVRT mode</b> is used.</p>	
7	LVRT mode	<p>Sets LVRT mode. The options are <b>Zero-current mode</b>, <b>Constant current mode</b>, <b>Reactive power priority mode</b>, and <b>Active power priority mode</b>.</p>	
8	LVRT characteristic curve	<p>Specifies the low voltage ride-through capability of the inverter.</p>	
9	HVRT	<p>HVRT is short for high voltage ride-through. When the grid voltage is abnormally high for a short time, the inverter cannot disconnect from the power grid immediately and has to work for some time.</p>	-

No.	Parameter	Description	Remarks
10	Threshold for triggering HVRT (V)	Specifies the threshold for triggering HVRT. The threshold settings should meet the local grid standard.	This parameter is displayed when <b>HVRT</b> is set to <b>Enable</b> .
11	HVRT gradient K1	During HVRT, the solar inverter needs to generate positive-sequence reactive power to support the power grid. This parameter is used to set the positive-sequence reactive power generated by the solar inverter. For example, if you set <b>HVRT gradient K1</b> to <b>2</b> , the positive-sequence reactive current generated by the solar inverter is 20% of the rated current when the AC voltage increases by 10% during HVRT.	
12	HVRT gradient K2	During HVRT, the solar inverter needs to generate negative-sequence reactive power to support the power grid. This parameter is used to set the negative-sequence reactive power generated by the solar inverter. For example, if you set <b>HVRT gradient K2</b> to <b>2</b> , the negative-sequence reactive current generated by the solar inverter is 20% of the rated current when the AC voltage increases by 10% during HVRT.	
13	Grid voltage protection shield during VRT	Specifies whether to shield the undervoltage protection function during LVRT or HVRT.	This parameter is displayed when <b>LVRT</b> or <b>HVRT</b> is set to <b>Enable</b> .
14	VRT exit hysteresis threshold	Specifies the LVRT/HVRT recovery threshold.	<ul style="list-style-type: none"> <li>• This parameter is displayed when <b>LVRT</b> or <b>HVRT</b> is set to <b>Enable</b>.</li> <li>• LVRT recovery threshold = Threshold for triggering LVRT + VRT exit hysteresis threshold</li> <li>• HVRT recovery threshold = Threshold for triggering HVRT - VRT exit hysteresis threshold</li> </ul>

No.	Parameter	Description	Remarks
15	Grid voltage jump triggering threshold (%)	Specifies the LVRT or HVRT threshold for triggering a transient voltage jump of a power grid. A transient voltage jump indicates that the inverter cannot immediately disconnect from the power grid when the power grid is abnormal due to transient changes.	-
16	Zero current due to power grid fault	Certain countries and regions have requirements on the output current during high/low voltage ride-through. In this case, set this parameter to <b>Enable</b> . After this parameter is set to <b>Enable</b> , the output current is less than 10% of the rated current during high/low voltage ride-through.	This parameter is displayed when <b>LVRT</b> or <b>HVRT</b> is set to <b>Enable</b> .
17	Active islanding protection	Specifies whether to enable the active islanding protection function.	-
18	Automatic OFF due to communication interrupted	The standards of certain countries and regions require that the inverter must shut down after the communication is interrupted for a certain time.	-
19	Automatic ON due to communication resumed	If this parameter is set to <b>Enable</b> , the inverter automatically starts after communication recovers. If this parameter is set to <b>Disable</b> , the inverter needs to be started manually after communication recovers.	-
20	Communication interruption duration (min)	Specifies the duration for determining communication interruption. Used for automatic shutdown for protection in case of communication interruption.	-
21	Soft start/boot time (s)	Specifies the duration for the power to gradually increase when the inverter starts.	-
22	Soft start time after grid failure (s)	Specifies the time for the power to gradually increase when the inverter restarts after the power grid recovers.	-
23	TCP heartbeat interval (s)	Specifies the TCP link timeout period for the solar inverter to connect to the management system.	-
24	TCP frame length	Specifies the maximum length of the TCP frame sent by the northbound device to the solar inverter.	-

No.	Parameter	Description	Remarks
25	Heartbeat period at application layer (min)	Specifies the timeout period for the solar inverter to connect to the management system.	-

### 7.1.5.4 Setting Power Adjustment Parameters

#### Procedure

**Step 1** Choose **Function Menu > Settings > Power Adjustment** to go to the parameter setting screen.

**Figure 7-13** Power adjustment parameters (special user)

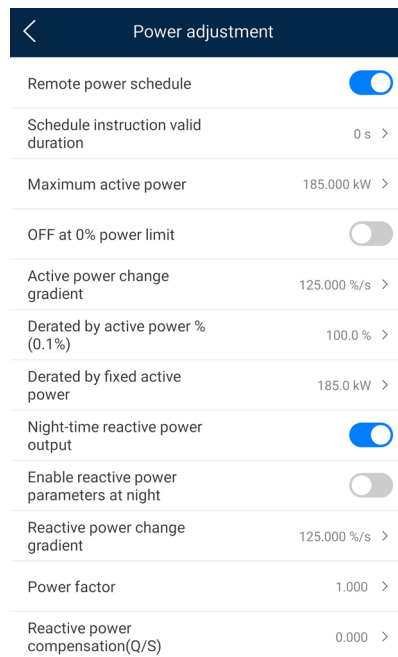

----End

#### Parameters

No.	Parameter	Description	Remarks
1	Remote power schedule	If this parameter is set to <b>Enable</b> , the inverter responds to the scheduling instruction from the remote port. If this parameter is set to <b>Disable</b> , the inverter does not respond to the scheduling instruction from the remote port.	-

No.	Parameter	Description	Remarks
2	Schedule instruction valid duration (s)	Specifies the time for maintaining the scheduling instruction.	When this parameter is set to 0, the scheduling instruction takes effect permanently.
3	Maximum active power (kW)	Specifies the output upper threshold for the maximum active power to adapt to different market requirements.	-
4	OFF at 0% power limit	If this parameter is set to <b>Enable</b> , the inverter shuts down after receiving the 0% power limit command. If this parameter is set to <b>Disable</b> , the inverter does not shut down after receiving the 0% power limit command.	-
5	Active power change gradient (%/s)	Specifies the change speed of the inverter active power.	-
6	Derated by fixed active power (kW)	Adjusts the active power output of the inverter by fixed value.	-
7	Derated by active power % (%)	Adjusts the active power output of the inverter by percentage.	If this parameter is set to <b>100</b> , the inverter outputs based on the maximum output power.
8	Night-time reactive power output	In some specific application scenarios, a power grid company requires that the inverter can perform reactive power compensation at night to ensure that the power factor of the local power grid meets requirements.	-
9	Enable reactive power parameters at night	When this parameter is set to <b>Enable</b> , the inverter outputs reactive power based on the setting of <b>Reactive power compensation at night</b> . Otherwise, the inverter executes the remote scheduling command.	This parameter is displayed when <b>Night-time reactive power output</b> is set to <b>Enable</b> .
10	Night-time reactive power compensation (kVar)	During the reactive power compensation at night, the reactive power is scheduled by fixed value.	This parameter is displayed when <b>Night-time reactive power output</b> and <b>Enable reactive power parameters at night</b> are set to <b>Enable</b> .

No.	Parameter	Description	Remarks
11	Reactive power change gradient (%/s)	Specifies the change speed of the inverter reactive power.	-
12	Plant active power gradient (min/100%)	Specifies the rate of active power rise due to sunlight changes.	-
13	Average active power filtering time (ms)	Specifies the period of active power rise due to sunlight changes. This parameter is used with <b>Plant active power gradient</b> .	-
14	Power factor	Specifies the power factor of the inverter.	-
15	Reactive power compensation (Q/S)	Specifies the reactive power output by the inverter.	-
16	Overfrequency derating	If this parameter is set to <b>Enable</b> , the active power of the inverter will be derated according to a certain slope when the grid frequency exceeds the frequency that triggers overfrequency derating.	-
17	Frequency for triggering overfrequency derating (Hz)	The standards of certain countries and regions require that the output active power of inverters be derated when the power grid frequency exceeds a certain value.	<ul style="list-style-type: none"> <li>• This parameter is displayed when <b>Overfrequency derating</b> is set to <b>Enable</b>.</li> <li>• When setting this parameter, ensure that the following condition is met: <b>Frequency for exiting overfrequency derating</b> ≤ <b>Frequency for triggering overfrequency derating</b> &lt; <b>Cutoff frequency of overfrequency derating</b>.</li> </ul>
18	Frequency for exiting overfrequency derating (Hz)	Specifies the frequency threshold for exiting overfrequency derating.	
19	Cutoff frequency of overfrequency derating (Hz)	Specifies the frequency threshold for cutting off overfrequency derating.	
20	Cutoff power of overfrequency derating (%)	Specifies the power threshold for cutting off overfrequency derating.	
21	Power recovery gradient of overfrequency derating (%/min)	Specifies the recovery rate of the overfrequency derating power.	
22	PF (U) voltage detection filtering time (s)	Specifies the time for filtering the grid voltage in the PF-U curve.	

No.	Parameter	Description	Remarks
23	Apparent power baseline (kVA)	Adjust the apparent output baseline of the inverter.	-
24	Active power baseline (kW)	Adjusts the active output baseline of the inverter.	-
25	Power percentage for triggering Q-U scheduling	Specifies the reference apparent power, in percentage. When the actual apparent power of the inverter is greater than the value of this parameter, the Q-U characteristic curve scheduling function is enabled.	-
26	Q-U characteristic curve	The inverter adjusts Q/S (the ratio of the output reactive power to apparent power) in real time based on U/Un(%) (the ratio of the actual power grid voltage to the rated power grid voltage).	-
27	Q-P characteristic curve	The inverter adjusts Q/Pn (the ratio of the output reactive power to the rated active power) in real time based on P/Pn(%) (the ratio of the actual active power to the rated active power).	-
28	Cos $\phi$ -P/Pn characteristic curve	The inverter adjusts the output power factor cos $\phi$ in real time based on P/Pn(%) .	-

## 7.2 Operations with a USB Flash Drive

USB flash drives of SanDisk, Netac, or Kingston are supported. Other USB flash drives may not be identified because they are not tested for compatibility.

### NOTE

Delete the script file immediately after use to reduce information disclosure risks.

### 7.2.1 Exporting Configurations

#### Procedure

1. Click **Local maintenance script** on the app to generate a boot script file, see the *FusionSolar APP and SUN2000 APP User Manual*.
2. Import the boot script file to a PC.  
(Optional) The boot script file can be opened as a .txt file.

**Figure 7-14** Boot script file

```

1 user engineer
2 psw 7e7bc842b22a991d864faecabe20424f79b3e1977286decaa5ae8753d57eae7f
3 validity duration xxxx-12-31 23:59:59
4 export param
    
```

No.	Meaning	Remarks
1	User name	<ul style="list-style-type: none"> <li>Advanced user: engineer</li> <li>Special user: admin</li> </ul>
2	Ciphertext	The ciphertext varies depending on the login password of the SUN2000 app or entering the <b>Device Commissioning</b> screen on the FusionSolar app.
3	Script validity period	-
4	Command	Different command settings can produce different commands. <ul style="list-style-type: none"> <li>Configuration export command: export param.</li> <li>Configuration import command: import param.</li> <li>Data export command: export log.</li> <li>Upgrade command: upgrade.</li> </ul>

- Import the boot script file to the root directory of a USB flash drive.
- Connect the USB flash drive to the USB port. The system automatically identifies the USB flash drive and executes all commands specified in the boot script file. View the LED indicator to determine the operating status.

**NOTICE**

Ensure that the ciphertext in the boot script matches the login password for logging in to the SUN2000 app or entering the Device Commissioning screen on the FusionSolar app. Otherwise, the user account will be locked for 10 minutes after the USB flash drive is inserted for five consecutive times.

**Table 7-1** LED indicator description

LED Indicator	Status	Meaning
	Green off	There is no operation with a USB flash drive.
	Blinking green slowly	There is an operation with a USB flash drive.
	Blinking green fast	An operation with a USB flash drive has failed.
	Steady green	An operation with a USB flash drive is successful.

5. Insert the USB flash drive into a computer and check the exported data.

 **NOTE**

When the configuration export is complete, the boot script file and exported file are in the root directory of the USB flash drive.

## 7.2.2 Importing Configurations

### Prerequisites

A complete configuration file has been exported.

### Procedure

1. Click **Local maintenance script** on the app to generate a boot script file, see the *FusionSolar APP and SUN2000 APP User Manual*.
2. Import the boot script file to a PC.
3. Replace the exported boot script file in the root directory of the USB flash drive with the imported one.

---

**NOTICE**

Replace the boot script file only and keep the exported files.

---

4. Connect the USB flash drive to the USB port. The system automatically identifies the USB flash drive and executes all commands specified in the boot script file. View the LED indicator to determine the operating status.

**NOTICE**

Ensure that the ciphertext in the boot script matches the login password for logging in to the SUN2000 app or entering the Device Commissioning screen on the FusionSolar app. Otherwise, the user account will be locked for 10 minutes after the USB flash drive is inserted for five consecutive times.

**Table 7-2** LED indicator description

LED Indicator	Status	Meaning
	Green off	There is no operation with a USB flash drive.
	Blinking green slowly	There is an operation with a USB flash drive.
	Blinking green fast	An operation with a USB flash drive has failed.
	Steady green	An operation with a USB flash drive is successful.

### 7.2.3 Exporting Data

#### Procedure

1. Click **Local maintenance script** on the app to generate a boot script file, see the *FusionSolar APP and SUN2000 APP User Manual*.
2. Import the boot script file to the root directory of a USB flash drive.
3. Connect the USB flash drive to the USB port. The system automatically identifies the USB flash drive and executes all commands specified in the boot script file. View the LED indicator to determine the operating status.

**NOTICE**

Ensure that the ciphertext in the boot script matches the login password for logging in to the SUN2000 app or entering the Device Commissioning screen on the FusionSolar app. Otherwise, the user account will be locked for 10 minutes after the USB flash drive is inserted for five consecutive times.

**Table 7-3** LED indicator description

LED Indicator	Status	Meaning
	Green off	There is no operation with a USB flash drive.
	Blinking green slowly	There is an operation with a USB flash drive.
	Blinking green fast	An operation with a USB flash drive has failed.
	Steady green	An operation with a USB flash drive is successful.

## 7.2.4 Upgrading

### Procedure

1. Download the required software upgrade package from the technical support website.
2. Decompress the upgrade package.

 **NOTE**

If the login password for logging in to the SUN2000 app or entering the **Device Commissioning** screen on the FusionSolar app is the initial password, you do not need to perform steps 3 to 5. If not, perform steps 3 to 7.

3. Click **Local maintenance script** on the app to generate a boot script file, see the *FusionSolar APP and SUN2000 APP User Manual*.
4. Import the boot script file to a PC.
5. Replace the boot script file (sun\_lmt\_mgr\_cmd.emap) in the upgrade package with the one generated by the app.
6. Copy the extracted files to the root directory of the USB flash drive.
7. Connect the USB flash drive to the USB port. The system automatically identifies the USB flash drive and executes all commands specified in the boot script file. View the LED indicator to determine the operating status.

**NOTICE**

Ensure that the ciphertext in the boot script matches the login password for logging in to the SUN2000 app or entering the Device Commissioning screen on the FusionSolar app. Otherwise, the user account will be locked for 10 minutes after the USB flash drive is inserted for five consecutive times.

**Table 7-4** LED indicator description

LED Indicator	Status	Meaning
	Green off	There is no operation with a USB flash drive.
	Blinking green slowly	There is an operation with a USB flash drive.
	Blinking green fast	An operation with a USB flash drive has failed.
	Steady green	An operation with a USB flash drive is successful.

8. The system automatically restarts when the upgrade is completed. All LED indicators are off during the restart. After the restart, the indicator is blinking green slowly for 1 minute and then it becomes steady green, which indicates that the upgrade is successful.

# 8 Maintenance

---

## 8.1 System Power-Off

### Precautions

---

 **WARNING**

- If two inverters share the same AC switch on the AC side, power off the two inverters.
  - After the inverter powers off, the remaining electricity and heat may still cause electric shocks and body burns. Therefore, put on personal protective equipment (PPE) and begin servicing the inverter fifteen minutes after power-off.
- 

### Procedure

**Step 1** Run a shutdown command on the SUN2000 app, SmartLogger, or network management system (NMS).

For details, see the user manual of the corresponding product.

**Step 2** Turn off the AC switch between the inverter and the power grid.

**Step 3** Set the three DC switches to OFF.

----End

## 8.2 Power-Off for Troubleshooting

### Context

To prevent personal injury and equipment damage, perform the following procedure to power off the solar inverter for troubleshooting or replacement.

**CAUTION**

- When a solar inverter is faulty, try to avoid standing in front of the solar inverter.
- Do not operate the DC switch on the solar inverter before you finish **Step 3** to **Step 5**.
- If the AC switch between the solar inverter and the power grid has automatically disconnected, do not turn on the switch before the fault is rectified.
- Before power-off for troubleshooting, do not touch the energized components of the solar inverter. Otherwise, electric shocks or arcing may occur.

**Procedure**

- Step 1** Wear proper personal protective equipment (PPE).
- Step 2** If the solar inverter is not shut down due to a fault, send a shutdown command on the SUN2000 app, SmartLogger, or management system. If the solar inverter has shut down due to a fault, go to the next step.
- Step 3** Turn off the AC switch between the solar inverter and the power grid.
- Step 4** Measure the DC current of each PV input string using a clamp meter that is set to the DC position.
- If the current is less than or equal to 0.5 A, go to the next step.
  - If the current is higher than 0.5 A, wait until the solar irradiance decreases and the PV string current decreases below 0.5 A at night, and then go to the next step.
- Step 5** Open the maintenance compartment door, install a support bar, and use a multimeter to measure the voltage between the AC terminal block and the ground. Ensure that the AC side of the solar inverter is disconnected.
- Step 6** Turn off all DC input switches of the solar inverter.

**Figure 8-1** Power-off for maintenance

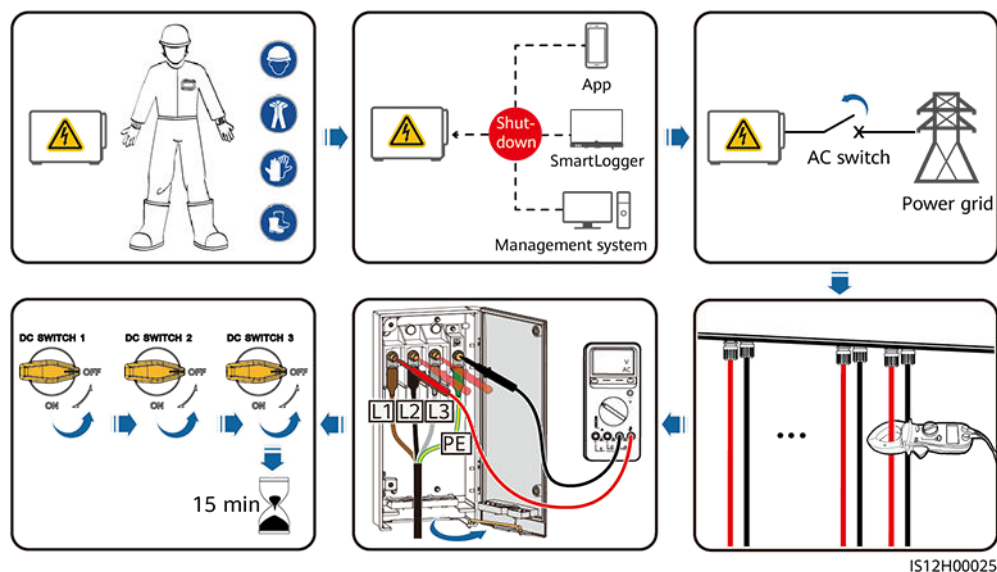

IS12H00025

**Step 7** Wait for 15 minutes and troubleshoot or repair the inverter.

---

 **WARNING**

- Do not open the host panel for maintenance if the solar inverter is emitting odor or smoke, or has obvious exceptions.
  - If the solar inverter does not emit odor or smoke and is intact, repair or restart it based on the alarm handling suggestions. Do not stand in front of the solar inverter during the restart.
- 

----End

## 8.3 Routine Maintenance

### Maintenance Item

To ensure that the inverter can operate properly for a long term, you are advised to perform routine maintenance on it as described in this chapter.

---

 **CAUTION**

- Before cleaning the system, connecting cables, and maintaining the grounding reliability, power off the system and ensure that the three DC switches on the inverter are OFF.
  - If you need to open the maintenance compartment door in rainy or snowy days, take protective measures to prevent rain or snow entering the maintenance compartment. If unavoidable, do not open the maintenance compartment door.
- 

Maintenance list

Item	Check Method	Maintenance Interval
<ul style="list-style-type: none"><li>• Cleanness of air intake and exhaust vents</li><li>• Fans</li></ul>	<ul style="list-style-type: none"><li>• Check whether there is dust on the air intake and exhaust vents. If necessary, remove the baffle of the air intake vent.</li><li>• Check whether the fans produce abnormal sounds during operation.</li></ul>	Once every 6 to 12 months

Item	Check Method	Maintenance Interval
System running status	<ul style="list-style-type: none"> <li>• The inverter is not damaged or deformed.</li> <li>• The inverter operates with no abnormal sound.</li> <li>• When the inverter is running, check whether all inverter parameters are correctly set.</li> </ul>	Once every 6 months
Electrical connections	<ul style="list-style-type: none"> <li>• Cables are securely connected.</li> <li>• Cables are intact, and in particular, the parts touching the metallic surface are not scratched.</li> <li>• Check whether the sealing caps of idle DC input terminals fall off.</li> <li>• Check that the idle COM and USB ports are locked by waterproof caps.</li> </ul>	The first inspection is 6 months after the initial commissioning. From then on, the interval can be 6 or 12 months.
Grounding reliability	Ground cables are securely connected.	The first inspection is 6 months after the initial commissioning. From then on, the interval can be 6 or 12 months.

## Removing the baffle of the air intake vent

Figure 8-2 Removing the baffle

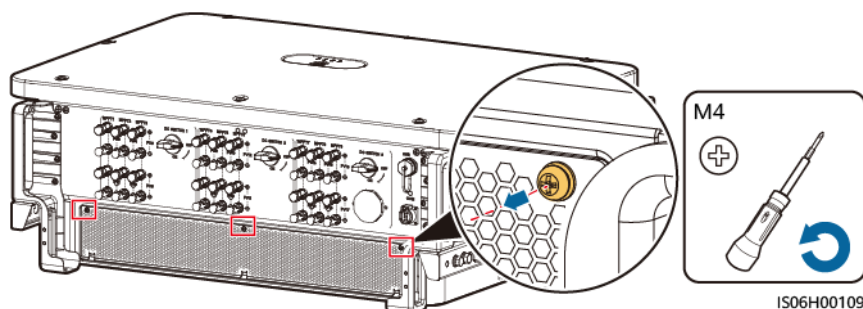

## 8.4 Replacing a Fan

### CAUTION

- Before replacing a fan, power off the inverter.
- When replacing a fan, use insulation tools and wear personal protective devices.

### NOTE

If the fan tray gets stuck when being pulled or pushed, slightly lift it.

- Step 1** Remove the screw on the fan tray and save it. Pull out the fan tray until the fan baffle plate aligns with the inverter chassis.

**Figure 8-3** Pulling out fan tray (1)

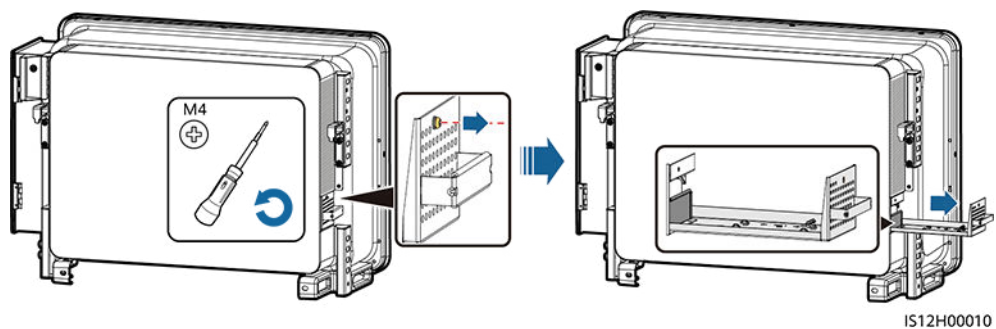

- Step 2** Remove the cable ties shared by the cables, unscrew the connectors, and disconnect the cables.

**Figure 8-4** Disconnecting cables

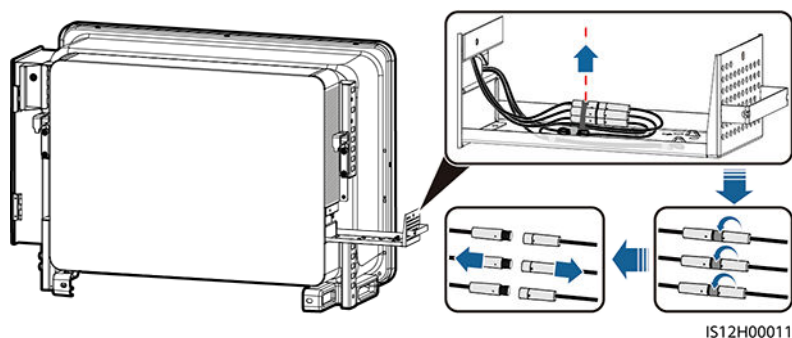

- Step 3** Pull out the fan tray.

**Figure 8-5** Pulling out fan tray (2)

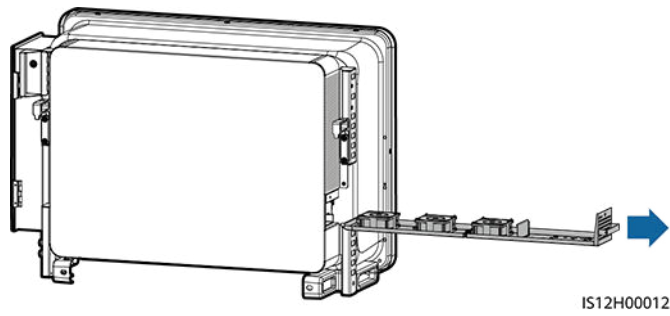

**Step 4** Remove cable ties from the faulty fan.

- FAN 1 Faulty

**Figure 8-6** Removing the FAN 1 cable ties

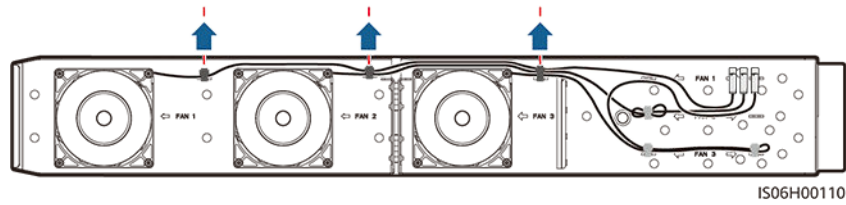

- FAN 2 Faulty

**Figure 8-7** Removing the FAN 2 cable ties

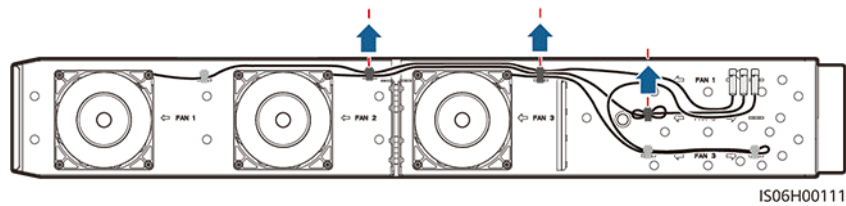

- FAN 3 Faulty

**Figure 8-8** Removing the FAN 3 cable ties

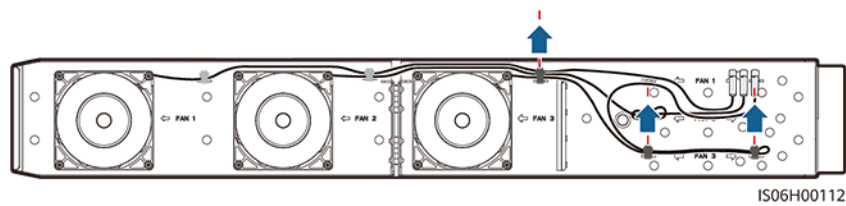

**Step 5** Remove the faulty fan (FAN 1 is used as an example).

**Figure 8-9** Removing the fan

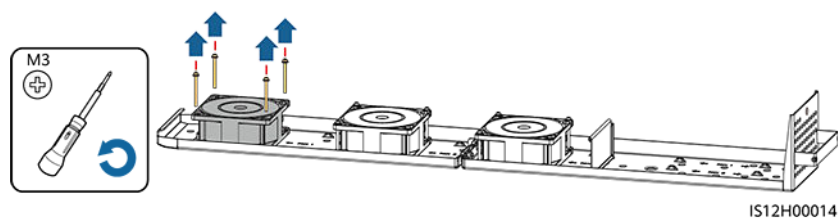

**Step 6** Install the new fan (FAN 1 is used as an example).

**Figure 8-10** Installing a new fan

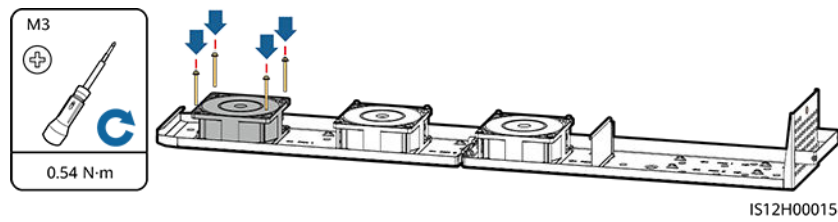

**Step 7** Bind the fan cables.

- Binding positions for fan 1

**Figure 8-11** Binding the FAN 1 cables

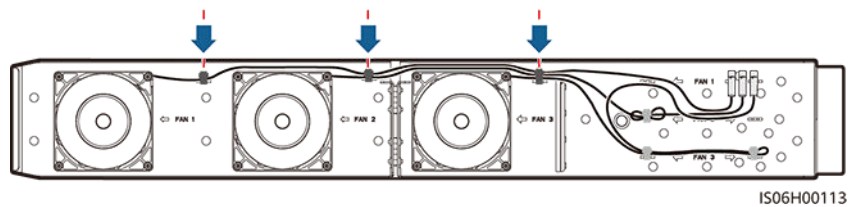

- Binding positions for fan 2

**Figure 8-12** Binding the FAN 2 cables

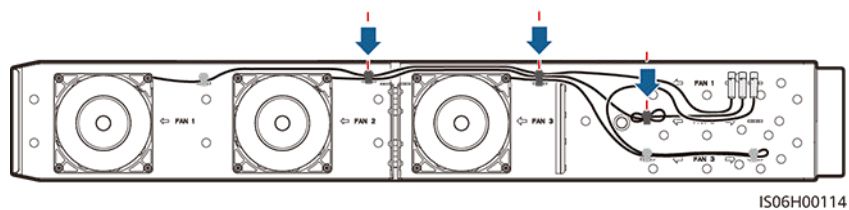

- Binding positions for fan 3

**Figure 8-13** Binding the FAN 3 cables

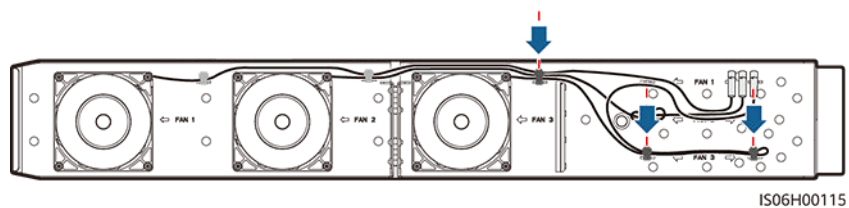

**Step 8** Push the fan tray into the slot until the fan baffle plate aligns with the inverter chassis.

**Figure 8-14** Pushing the fan tray in

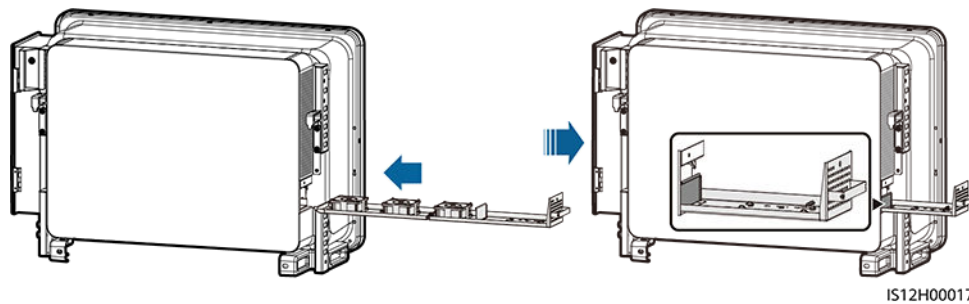

**Step 9** Connect the cables correctly according to the cable labels and bind the cables.

**Figure 8-15** Reconnecting and binding the cables

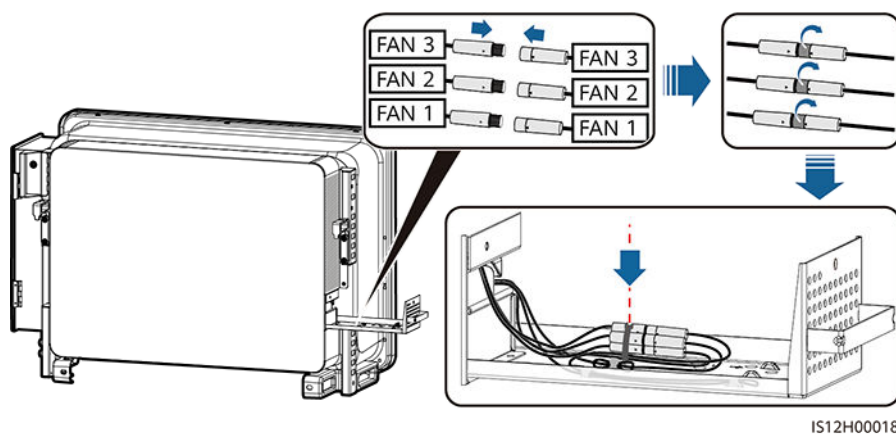

**Step 10** Push the fan tray into the slot and tighten the screw.

**Figure 8-16** Reinstalling the fan tray

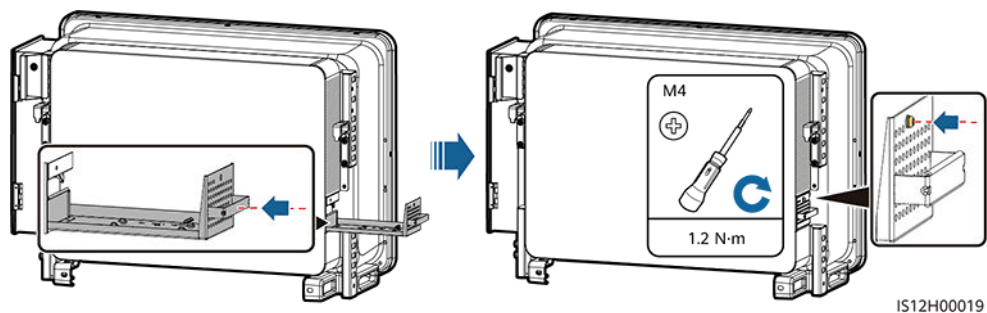

----End

## 8.5 Troubleshooting

Alarm severities are defined as follows:

- Major: The inverter is faulty. As a result, the output power decreases or the grid-tied power generation is stopped.
- Minor: Some components are faulty without affecting the grid-tied power generation.

- Warning: The inverter works properly. The output power decreases or some authorization functions fail due to external factors.

**Table 8-1** Common alarms and troubleshooting measures

Alarm ID	Alarm Name	Alarm Severity	Cause	Troubleshooting Suggestions
2001	High String Input Voltage	Major	<p>The PV array is not properly configured. Excessive PV modules are connected in series to a PV string, and therefore the PV string open-circuit voltage exceeds the maximum operating voltage of the inverter.</p> <ul style="list-style-type: none"> <li>• Cause ID 1: PV strings 1 and 2.</li> <li>• Cause ID 2: PV strings 3 and 4.</li> <li>• Cause ID 3: PV strings 5 and 6.</li> <li>• Cause ID 4: PV strings 7 and 8.</li> <li>• Cause ID 5: PV strings 9 and 10.</li> <li>• Cause ID 6: PV strings 11 and 12.</li> <li>• Cause ID 7: PV strings 13 and 14.</li> <li>• Cause ID 8: PV strings 15 and 16.</li> <li>• Cause ID 9: PV strings 17 and 18.</li> </ul>	<p>Reduce the number of PV modules connected in series in the PV string until the PV string open-circuit voltage is not greater than the maximum operating voltage of the inverter. After the PV array configuration is corrected, the alarm disappears.</p>
2011	String Reverse Connection	Major	<p>The PV string is reversely connected.</p> <p>Cause ID 1-18: PV strings 1-18</p>	<p>Check whether the PV string is reversely connected to the inverter. If yes, wait until the PV string current drops below 0.5 A. Then, set all DC switches to OFF and correct the PV string connection.</p>

Alarm ID	Alarm Name	Alarm Severity	Cause	Troubleshooting Suggestions
2012	String Current Backfeed	Warning	1. Only a few PV modules are connected in series in the PV string. Therefore, the end voltage is lower than that of other PV strings. 2. The PV string is shaded. Cause ID 1-18: PV strings 1-18	1. Check whether the number of PV modules connected in series in the PV string is less than that in other PV strings connected in parallel with this PV string. If yes, wait until the PV string current drops below 0.5 A, set all DC switches to OFF, and adjust the number of PV modules in the PV string. 2. Check whether the open-circuit voltage of the PV string is normal. 3. Check whether the PV string is shaded.

Alarm ID	Alarm Name	Alarm Severity	Cause	Troubleshooting Suggestions
2014	High input string voltage to ground	Major	Cause ID = 1 The voltage between the input PV modules and the ground is abnormal, and there is a risk of power degradation.	<ol style="list-style-type: none"> <li>1. If no PID compensation device exists in the system, disable the PID protection function at night. Note: If the PID protection function is disabled but reactive power compensation at night is enabled, PV modules may be degraded.</li> <li>2. If the system has a PID compensation device, check whether the device is abnormal. If yes, rectify the fault.</li> <li>3. Check whether the settings of compensation direction for the inverter and the PID compensation device are consistent. If not, set them to be consistent based on the PV module model.                      (Note: If the PV- is set to positive offset, the voltage between the inverter PV- and the ground should be greater than 0 V to clear the alarm; if the PV+ is set to negative offset, the voltage between the inverter PV+ and the ground should be less than 0 V to clear the alarm.)</li> <li>4. If the alarm persists, contact your dealer or Huawei technical support.</li> </ol>

Alarm ID	Alarm Name	Alarm Severity	Cause	Troubleshooting Suggestions
2015	PV String Loss	Warning	<p>This alarm is generated when the PV string status is abnormal in the following conditions:</p> <ul style="list-style-type: none"> <li>• A single PV string is lost.</li> <li>• Both 2-in-1 PV strings are lost.</li> <li>• Either of the 2-in-1 PV strings is lost.</li> </ul> <p>Cause ID 1-8: PV strings 1-18</p>	<ol style="list-style-type: none"> <li>1. If the PV string access type is manually set, check whether it is consistent with the actual access status.</li> <li>2. Check whether the inverter terminals are properly connected.</li> <li>3. Check whether the PV string terminals are properly connected.</li> <li>4. If a 2-in-1 terminal is used, check whether it is normal.</li> </ol>
2031	Phase Wire Short-Circuited to PE	Major	<p>Cause ID=1</p> <p>The impedance of the output phase wire to PE is low or the output phase wire is short-circuited to PE.</p>	<p>Check the impedance of the output phase wire to PE, locate the position with lower impedance, and rectify the fault.</p>
2032	Grid Loss	Major	<p>Cause ID=1</p> <ol style="list-style-type: none"> <li>1. The power grid experiences an outage.</li> <li>2. The AC circuit is disconnected or the AC switch is off.</li> </ol>	<ol style="list-style-type: none"> <li>1. The alarm is automatically cleared after the power grid is restored.</li> <li>2. Check whether the AC circuit is disconnected or the AC switch is off.</li> </ol>

Alarm ID	Alarm Name	Alarm Severity	Cause	Troubleshooting Suggestions
2033	Grid Undervoltage	Major	Cause ID=1 The grid voltage is below the lower threshold or the undervoltage duration has exceeded the time that triggers LVRT.	<ol style="list-style-type: none"> <li>1. If the alarm occurs occasionally, the power grid may be abnormal temporarily. The inverter automatically recovers after detecting that the power grid becomes normal.</li> <li>2. If the alarm occurs frequently, check whether the power grid voltage is within the acceptable range. If not, contact the local power operator. If yes, modify the grid undervoltage protection threshold through the mobile app, SmartLogger, or network management system (NMS) with the consent of the local power operator.</li> <li>3. If the fault persists for a long time, check the AC circuit breaker and AC output power cable.</li> </ol>
2034	Grid Overvoltage	Major	Cause ID=1 The grid voltage is beyond the upper threshold or the overvoltage duration has exceeded the time that triggers HVRT.	<ol style="list-style-type: none"> <li>1. Check whether the grid connection voltage exceeds the upper threshold. If yes, contact the local power operator.</li> <li>2. If you have confirmed that the grid-tied voltage exceeds the upper threshold and have obtained the consent of the local power operator, modify the overvoltage protection threshold through the mobile app, SmartLogger, or NMS.</li> <li>3. Check whether the peak grid voltage exceeds the upper threshold.</li> </ol>

Alarm ID	Alarm Name	Alarm Severity	Cause	Troubleshooting Suggestions
2035	Grid Voltage Imbalance	Major	Cause ID=1 The difference between grid phase voltages exceeds the upper threshold.	<ol style="list-style-type: none"> <li>1. Check that the grid voltage is within the normal range.</li> <li>2. Check that the AC output power cable is correctly connected. If the AC output power cable is correctly connected, yet the alarm persists and affects the energy yield of the power plant, contact the local power operator.</li> </ol>
2036	Grid Overfrequency	Major	Cause ID=1 Power grid exception: The actual power grid frequency is higher than the standard requirement for the local power grid.	<ol style="list-style-type: none"> <li>1. If the alarm occurs occasionally, the power grid may be abnormal temporarily. The inverter automatically recovers after detecting that the power grid becomes normal.</li> <li>2. If the alarm occurs frequently, check whether the power grid frequency is within the acceptable range. If not, contact the local power operator. If yes, modify the grid overfrequency protection threshold through the mobile app, SmartLogger, or NMS with the consent of the local power operator.</li> </ol>

Alarm ID	Alarm Name	Alarm Severity	Cause	Troubleshooting Suggestions
2037	Grid Underfrequency	Major	Cause ID=1 Power grid exception: The actual power grid frequency is lower than the standard requirement for the local power grid.	<ol style="list-style-type: none"> <li>1. If the alarm occurs occasionally, the power grid may be abnormal temporarily. The inverter automatically recovers after detecting that the power grid becomes normal.</li> <li>2. If the alarm occurs frequently, check whether the power grid frequency is within the acceptable range. If not, contact the local power operator. If yes, modify the grid underfrequency protection threshold through the mobile app, SmartLogger, or NMS with the consent of the local power operator.</li> </ol>
2038	Unstable Grid Frequency	Major	Cause ID=1 Power grid exception: The actual grid frequency change rate does not comply with the local power grid standard.	<ol style="list-style-type: none"> <li>1. If the alarm occurs occasionally, the power grid may be abnormal temporarily. The inverter automatically recovers after detecting that the power grid becomes normal.</li> <li>2. If the alarm occurs frequently, check whether the power grid frequency is within the acceptable range. If not, contact the local power operator.</li> </ol>

Alarm ID	Alarm Name	Alarm Severity	Cause	Troubleshooting Suggestions
2039	Output Overcurrent	Major	<p>Cause ID=1</p> <p>The power grid voltage drops dramatically or the power grid is short-circuited. As a result, the inverter transient output current exceeds the upper threshold and therefore the inverter protection is triggered.</p>	<ol style="list-style-type: none"> <li>1. The inverter detects its external working conditions in real time. After the fault is rectified, the inverter automatically recovers.</li> <li>2. If the alarm occurs frequently and affects the energy yield of the power plant, check whether the output is short-circuited. If the fault cannot be rectified, contact your dealer or Huawei technical support.</li> </ol>
2040	Output DC Component Overhigh	Major	<p>Cause ID=1</p> <p>The DC component of the inverter output current exceeds the specified upper threshold.</p>	<ol style="list-style-type: none"> <li>1. If the exception is caused by an external fault, the inverter automatically recovers after the fault is rectified.</li> <li>2. If this alarm occurs frequently and affects the energy yield of the PV plant, contact your dealer or Huawei technical support.</li> </ol>
2051	Abnormal Residual Current	Major	<p>Cause ID=1</p> <p>The insulation impedance of the input side to PE decreases when the inverter is operating.</p>	<ol style="list-style-type: none"> <li>1. If the alarm occurs occasionally, the external circuit may be abnormal temporarily. The inverter automatically recovers after the fault is rectified.</li> <li>2. If the alarm occurs frequently or persists, check whether the impedance between the PV string and the ground is too low.</li> </ol>

Alarm ID	Alarm Name	Alarm Severity	Cause	Troubleshooting Suggestions
2062	Low Insulation Resistance	Major	Cause ID=1 1. The PV string is short-circuited to the PE cable. 2. The PV string has been in a moist environment for a long time and the circuit is not well insulated to ground.	1. Check the impedance of the PV string to PE. If a short circuit occurs, rectify it. 2. Check that the ground cable of the inverter is correctly connected. 3. If you are sure that the impedance is less than the preset value in a cloudy or rainy environment, reset <b>Insulation resistance protection</b> .
2063	Cabinet Overtemperature	Minor	Cause ID=1 1. The inverter is installed in a place with poor ventilation. 2. The ambient temperature is too high. 3. The inverter is not working properly.	1. Check the ventilation and whether the ambient temperature of the inverter exceeds the upper limit. If the ventilation is poor or the ambient temperature is too high, improve ventilation. 2. If both the ventilation and ambient temperature meet requirements yet the fault persists, contact your dealer or Huawei technical support.
2064	Device Fault	Major	Cause ID=1 An unrecoverable fault has occurred on a circuit inside the inverter.	Turn off the AC output switch and DC input switch, and then turn them on after 15 minutes. If the fault persists, contact your dealer or Huawei technical support.
2065	Upgrade Failed or Software Version Unmatch	Minor	Cause ID=1 The upgrade does not complete normally.	1. Perform an upgrade again. 2. If the upgrade fails several times, contact your dealer.
2066	License Expired	Warning	Cause ID=1 1. The privilege license has entered the grace period. 2. The privilege feature will be invalid soon.	1. Apply for a new license. 2. Load a new license.

Alarm ID	Alarm Name	Alarm Severity	Cause	Troubleshooting Suggestions
2086	External fan abnormal	Major	External fan short-circuited, power supply insufficient, or air channel blocked Cause ID 1-3: fans 1-3	<ol style="list-style-type: none"> <li>1. Shut down the fan, turn off the DC switch, check whether the fan blades are damaged, and clear the foreign matter around the fan.</li> <li>2. Reinstall the fan, turn on the DC switch, and wait for the inverter to start. If the fault persists after 15 minutes, replace the external fan.</li> </ol>
2087	Internal fan abnormal	Major	Cause ID=1 The internal fan is short-circuited, the power supply is insufficient, or the fan is damaged.	Turn off the AC output switch and then the DC input switch. Turn them on after 5 minutes and wait for the inverter to connect to the power grid. If the fault persists, contact your dealer or Huawei technical support.
61440	Faulty Monitoring Unit	Minor	Cause ID=1 <ol style="list-style-type: none"> <li>1. The flash memory is insufficient.</li> <li>2. The flash memory has bad sectors.</li> </ol>	Turn off the AC output switch and DC input switch, and then turn them on after 15 minutes. If the fault persists, replace the monitoring board or contact your dealer or Huawei technical support.

 **NOTE**

If you cannot rectify faults with the measures listed in troubleshooting suggestions, contact your dealer or Huawei technical support.

# 9 Handling the Inverter

---

## 9.1 Removing the SUN2000

---

**NOTICE**

Before removing the SUN2000, disconnect both AC and DC connections.

---

Perform the following operations to remove the SUN2000:

1. Disconnect all cables from the SUN2000, including RS485 communications cables, DC input power cables, AC output power cables, and PGND cables.
2. Remove the SUN2000 from the mounting bracket.
3. Remove the mounting bracket.

## 9.2 Packing the SUN2000

- If the original packing materials are available, put the SUN2000 inside them and then seal them by using adhesive tape.
- If the original packing materials are not available, put the SUN2000 inside a suitable cardboard box and seal it properly.

## 9.3 Disposing of the SUN2000

If the SUN2000 service life expires, dispose of it according to the local disposal rules for electrical equipment waste.

# 10 Technical Data

## Efficiency

Technical Specifications	SUN2000-175KTL-H0	SUN2000-185KTL-INH0	SUN2000-185KTL-H1
Maximum efficiency	≥ 99.0%	≥ 99.0%	≥ 99.0%
Chinese efficiency	≥ 98.4%	-	-
European efficiency	-	≥ 98.6%	≥ 98.6%

## Input

Technical Specifications	SUN2000-175KTL-H0	SUN2000-185KTL-INH0	SUN2000-185KTL-H1
Maximum input voltage	1500 V		
Maximum input current (per MPPT)	26 A		
Maximum short-circuit current (per MPPT)	40 A		
Maximum backfeed current to the PV array	0 A		
Lowest operating/startup voltage	500 V/550 V		

Technical Specifications	SUN2000-175KTL-H0	SUN2000-185KTL-INH0	SUN2000-185KTL-H1
Operating voltage range	500–1500 V		
Full-load MPPT voltage range	880–1300 V		
Rated input voltage	1080 V		
Number of inputs	18		
Number of MPP trackers	9		

## Output

Technical Specifications	SUN2000-175KTL-H0	SUN2000-185KTL-INH0	SUN2000-185KTL-H1
Rated active power	175 kW	160 kW	175 kW
Maximum apparent power	193 kVA	185 kVA	185 kVA
Maximum active power (cos $\phi$ = 1)	193 kW	185 kW	185 kW
Rated output voltage	800 V AC, 3W+PE		
Rated output current	126.3 A	115.5 A (160 kW) 126.3 A (175 kW)	108.3 A (150 kW) 121.3 A (168 kW) 126.3 A (175 kW)
Adapted power grid frequency	50 Hz	50 Hz/60 Hz	50 Hz/60 Hz
Maximum output current	140.7 A	134.9 A	134.9 A
Power factor	0.8 leading and 0.8 lagging		
Maximum total harmonic distortion (rated power)	< 3%		

## Protection

Technical Specifications	SUN2000-175KTL-H0	SUN2000-185KTL-INH0	SUN2000-185KTL-H1
Input DC switch	Supported		
Anti-islanding protection	Supported		
Output overcurrent protection	Supported		
Input reverse connection protection	Supported		
PV string fault detection	Supported		
DC surge protection	Type II		
AC surge protection	Type II		
Insulation resistance detection	Supported		
Residue current monitoring (RCMU)	Supported		
Overvoltage category	PV II/AC III		

## Display and Communication

Technical Specifications	SUN2000-175KTL-H0	SUN2000-185KTL-INH0	SUN2000-185KTL-H1
Display	LED indicator, Bluetooth module+app, USB data cable+app, and WLAN module+app		
RS485	Supported		
MBUS	Supported		
USB	Supported		

## Common Parameters

Technical Specifications	SUN2000-175KTL-H0	SUN2000-185KTL-INH0	SUN2000-185KTL-H1
Dimensions (W x H x D)	1035 mm x 700 mm x 365 mm		
Net weight	84 kg±1 kg		
Operating temperature	-25°C to +60°C		
Cooling mode	Intelligent air cooling		
Highest operating altitude	5000 m (derated when the altitude is greater than 4000 m)		
Humidity	0%–100% RH		
Input terminal	MC4 EVO2		
Output terminal	Waterproof terminal+OT/DT terminal		
IP rating	IP66		
Topology	Transformerless		

# A Securing Y-Branch Connectors

The DC input terminals of the solar inverter are prone to damage under stress. When Y-branch connectors are connected to the solar inverter, bind and secure the connectors to prevent the DC input terminals from bearing stress. You are advised to install a tray or beam to secure the Y-branch connectors.

## Method 1: Using a Tray

Prepare a tray based on the base size of the solar inverter and the cabling of the Y-branch connectors.

- Material: outdoor corrosion-resistant material
- Bearing capacity:  $\geq 10$  kg

Figure A-1 Recommended dimensions

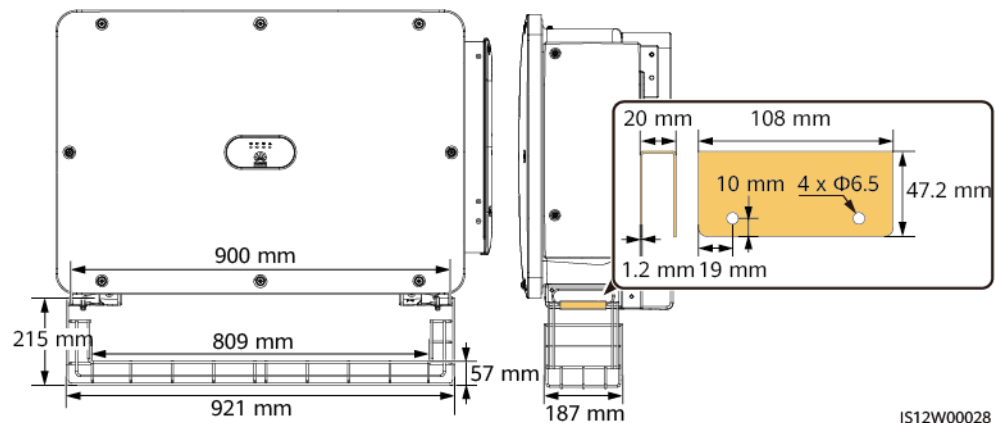

**Step 1** Install a tray.

**Figure A-2** Installing a tray

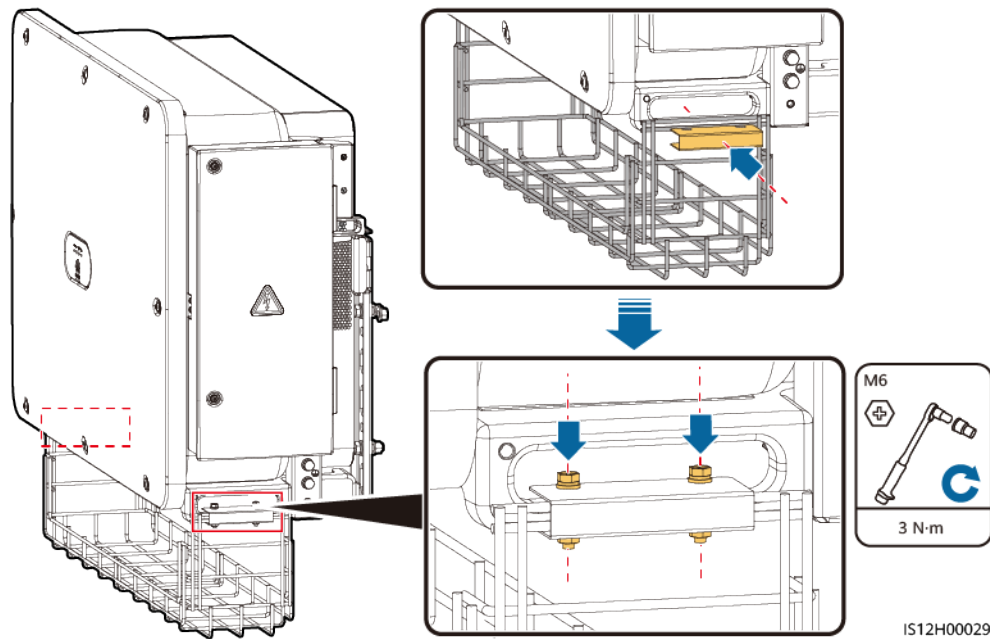

**Step 2** Place the Y-branch connectors on the tray.

**Figure A-3** Placing Y-branch connectors

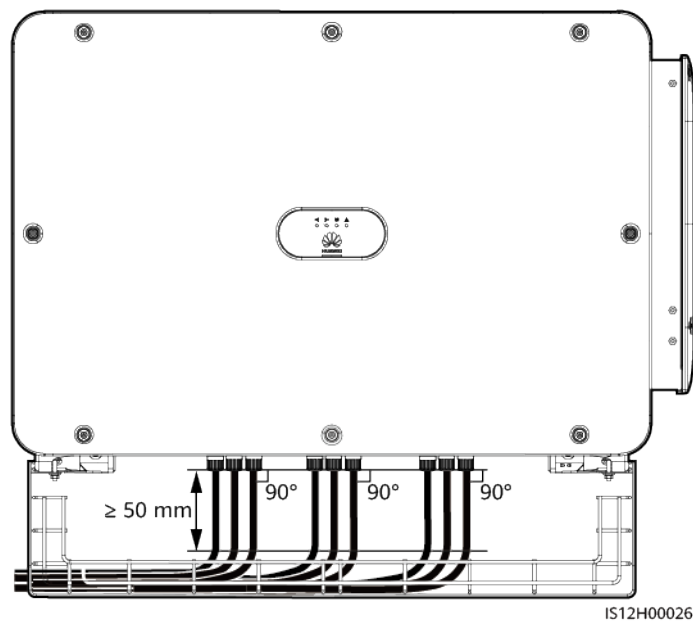

----End

## Method 2: Using a Beam

Prepare a beam based on the base size of the solar inverter and the cabling of the Y-branch connectors.

- Material: outdoor corrosion-resistant material
- Bearing capacity:  $\geq 10$  kg

**Figure A-4** Recommended dimensions

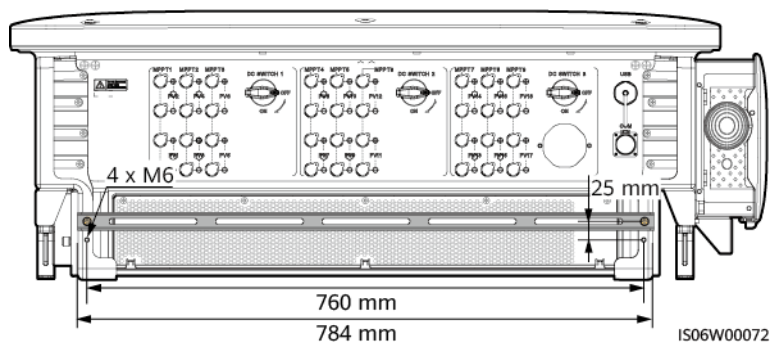

**Step 1** Install a beam.

**Figure A-5** Installing a beam

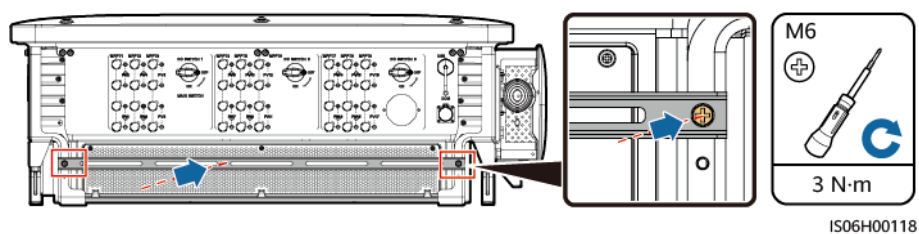

**Step 2** Bind the Y-branch connectors on the beam.

**Figure A-6** Binding Y-branch connectors

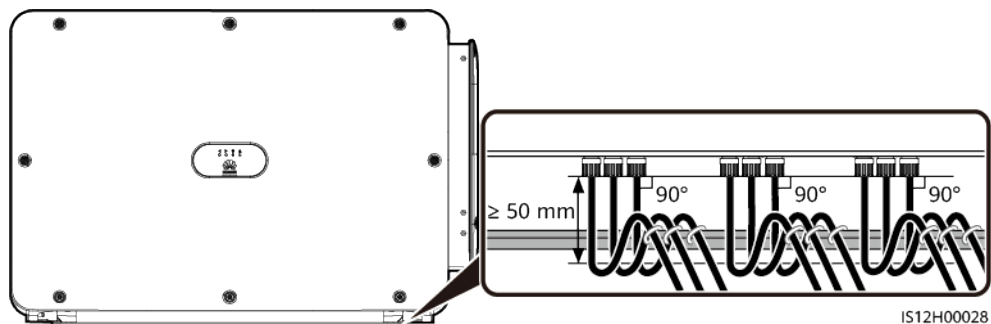

----End

# B String Access Detection

---

## Function Description

- Applies to large-scale commercial ground PV plants with PV strings facing the same direction.
- In AC or DC power limiting scenarios:
  - If the PV string access type is not identified, the value of **PV Status** will keep being displayed as **Not connected**. The PV string access type can be identified only when the inverters restore to the non-power limiting state and the current of all connected PV strings reaches the startup current.
  - If the PV string access type has been identified, when some PV strings connected to the 2-in-1 terminals are lost, no alarm will be generated. If some PV strings connected to the 2-in-1 terminals are restored, the access type cannot be identified. It can be determined whether all the 2-in-1 PV strings are restored only when the string current reaches **Startup current for 2 in 1 detection**.

## Procedure

**Step 1** Log in to the SUN2000 app as **Advanced User**. The initial password is **00000a**.

 **NOTE**

Use the initial password upon first power-on and change it immediately after login. To ensure account security, change the password periodically and keep the new password in mind. Not changing the initial password may cause password disclosure. A password left unchanged for a long period of time may be stolen or cracked. If a password is lost, devices cannot be accessed. In these cases, the user is liable for any loss caused to the PV plant.

**Step 2** Choose **Function Menu > Maintenance > String Access Detection** to go to the parameter setting screen.

**Figure B-1** String Access Detection

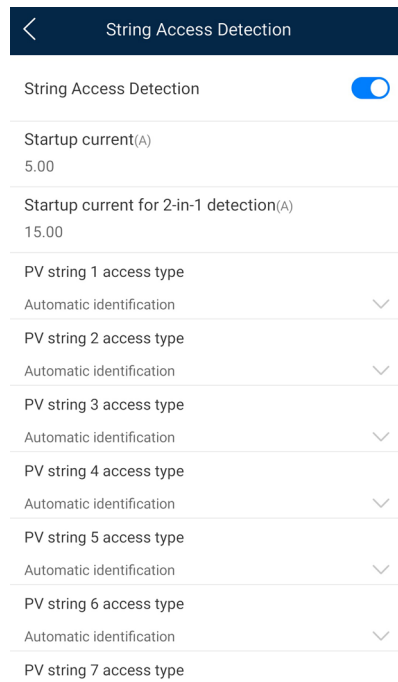

----End

## Parameters

No.	Parameter	Description	Remarks
1	String Access Detection	The default value is <b>Disable</b> . After the inverter is connected to the power grid, you can set <b>String Access Detection</b> to <b>Enable</b> .	-
2	Startup current	When the current of all connected PV strings reaches the preset value, the PV string connection detection function is enabled. <b>NOTE</b> Startup current setting rules: <ul style="list-style-type: none"> <li>Startup current = <math>I_{sc}(S_{tc}) \times 0.6</math> (rounded up). For details about <math>I_{sc}(S_{tc})</math>, see the PV module nameplate.</li> <li>Default startup current (5 A): applicable to the scenarios where the short-circuit current <math>I_{sc}(S_{tc})</math> is greater than 8 A for the monocrystalline and polycrystalline PV modules.</li> </ul>	This parameter is displayed only when <b>String Access Detection</b> is set to <b>Enable</b> .
3	Startup current for 2 in 1 detection	When the current of a PV string reaches <b>Startup current for 2 in 1 detection</b> , the PV string is automatically identified as <b>2 in 1</b> . You are advised to use the default value.	

No.	Parameter	Description	Remarks
4	PV string N access type <b>NOTE</b> N is the DC input terminal number of the inverter.	Set this parameter based on the type of the PV string connected to DC input terminal <i>N</i> of the inverter. Currently, the options are as follows: <b>Automatic identification</b> (default value), <b>Disconnection, Single PV string</b> , and <b>2 in 1</b> .  You are advised to retain the default value. If the value is incorrectly set, the PV string access type may be incorrectly identified and alarms may be generated by mistake for the PV string connection status.	

# C Domain Name List of Management Systems

---

 **NOTE**

The list is subject to change.

**Table C-1** Domain names of management systems

Domain Name	Data Type	Scenario
intl.fusionsolar.huawei.com	Public IP address	FusionSolar hosting cloud <b>NOTE</b> The domain name is compatible with cn.fusionsolar.huawei.com (Chinese mainland).

# D Grid Code

No.	Grid Code	Description	SUN2000-175KTL-H0	SUN2000-185KTL-INH0	SUN2000-185KTL-H1
1	CHINA_MV800	China medium-voltage power grid	Supported	-	-
2	G59-England-MV800	G59 medium-voltage power grid	-	-	Supported
3	AS4777-MV800	Australia medium-voltage power grid	-	-	Supported
4	INDIA-MV800	India medium-voltage power grid	-	Supported	-
5	IEC61727-MV800	IEC61727 medium-voltage power grid (50 Hz)	-	Supported	Supported
6	ABNT NBR 16149-MV800	Brazil medium-voltage power grid	-	Supported	Supported
7	UTE C 15-712-1-MV800	France medium-voltage power grid	-	-	Supported
8	Chile-MV800	Chile medium-voltage power grid	-	-	Supported
9	Mexico-MV800	Mexico power grid	-	-	Supported
10	EN50438-TR-MV800	Turkey medium-voltage power grid	-	-	Supported
11	TAI-PEA-MV800	Thailand PEA medium-voltage power grid	-	-	Supported
12	Philippines-MV800	Philippines medium-voltage power grid	-	-	Supported

No.	Grid Code	Description	SUN2000-175KTL-H0	SUN2000-185KTL-INH0	SUN2000-185KTL-H1
13	Malaysian-MV800	Malaysia medium-voltage power grid	-	-	Supported
14	NRS-097-2-1-MV800	South Africa medium-voltage power grid	-	-	Supported
15	SA_RPPs-MV800	South Africa RPPs medium-voltage power grid	-	-	Supported
16	Jordan-Transmission-MV800	Jordan power transmission network medium-voltage power grid	-	-	Supported
17	Jordan-Distribution-MV800	Jordan power distribution network medium-voltage power grid	-	-	Supported
18	Egypt ETEC-MV800	Egypt medium-voltage power grid	-	-	Supported
19	DUBAI-MV800	Dubai medium-voltage power grid	-	-	Supported
20	SAUDI-MV800	Saudi Arabia medium-voltage power grid	-	-	Supported
21	EN50438_IE-MV800	Ireland medium-voltage power grid	-	-	Supported
22	EN50549-MV800	Ireland power grid	-	-	Supported
23	Northern Ireland-MV800	Northern Ireland medium-voltage power grid	-	-	Supported
24	CEI0-21-MV800	Italy medium-voltage power grid (CEI0-21)	-	-	Supported
25	IEC 61727-MV800-60HZ	General medium-voltage power grid	-	Supported	Supported
26	Pakistan-MV800	Pakistan medium-voltage power grid	-	-	Supported
27	BRASIL-ANEEL-MV800	Brazil medium-voltage power grid	-	-	Supported
28	Israel-MV800	Israel power grid	-	-	Supported
29	CEI0-16-MV800	Italy medium-voltage power grid	-	-	Supported
30	ZAMBIA-MV800	Zambia medium-voltage power grid	-	-	Supported

No.	Grid Code	Description	SUN2000-175KTL-H0	SUN2000-185KTL-INH0	SUN2000-185KTL-H1
31	KENYA_ETHIOPIA_MV800	Kenya low-voltage and Ethiopia medium-voltage power grid	-	-	Supported
32	NAMIBIA_MV800	Namibia medium-voltage power grid	-	-	Supported
33	Cameroon-MV800	Cameroon medium-voltage power grid	-	-	Supported
34	NIGERIA-MV800	Nigeria medium-voltage power grid	-	-	Supported
35	ABUDHABI-MV800	Abu Dhabi medium-voltage power grid	-	-	Supported
36	LEBANON-MV800	Lebanon medium-voltage power grid	-	-	Supported
37	ARGENTINA-MV800	Argentina medium-voltage power grid	-	-	Supported
38	Jordan-Transmission-HV800	Jordan high-voltage and medium-voltage power grid	-	-	Supported
39	TUNISIA-MV800	Tunisia medium-voltage power grid	-	-	Supported
40	AUSTRALIA-NER-MV800	Australia NER standard medium-voltage power grid	-	-	Supported
41	VDE-AR-N4120_HV800	VDE4120 standard medium-voltage power grid	-	Supported	Supported
42	Nicaragua-MV800	Nicaragua medium-voltage power grid	-	-	Supported
43	Custom-MV800-50Hz	Reserved	-	-	Supported
44	RD1699/661-MV800	Spain medium-voltage power grid	-	-	Supported
45	PO12.3-MV800	Spain medium-voltage power grid	-	-	Supported
46	Vietnam-MV800	Vietnam medium-voltage power grid	-	-	Supported
47	CHILE-PMGD-MV800	Chile PMGD medium-voltage power grid (800 V)	-	-	Supported
48	GHANA-MV800	Ghana medium-voltage power grid (800 V)	-	-	Supported

No.	Grid Code	Description	SUN2000-175KTL-H0	SUN2000-185KTL-INH0	SUN2000-185KTL-H1
49	TAIPOWER-MV800	Taiwan power medium-voltage power grid (800 V)	-	-	Supported
50	OMAN-MV800	Oman medium-voltage power grid	-	-	Supported
51	KUWAIT-MV800	Kuwait medium-voltage power grid	-	-	Supported
52	BANGLADESH-MV800	Bangladesh medium-voltage power grid	-	-	Supported
53	BAHRAIN-MV800	Bahrain medium-voltage power grid	-	-	Supported
54	KAZAKHSTAN-MV800	Kazakhstan medium-voltage power grid	-	-	Supported
55	Oman-PDO-MV800	Oman PDO medium-voltage power grid	-	-	Supported
56	TAI-MEA-MV800	Thailand medium-voltage power grid	-	-	Supported
57	C10/11-MV800	Belgium medium-voltage power grid	-	-	Supported
58	G99-TYPEB-HV-MV800	UK G99_TypeB_HV medium-voltage power grid	-	-	Supported
59	G99-TYPEC-HV-MV800	UK G99_TypeC_HV medium-voltage power grid	-	-	Supported
60	G99-TYPED-MV800	UK G99_TypeD medium-voltage power grid	-	-	Supported
61	CEA-MV800	India CEA power grid	-	Supported	-
62	VDE-AR-N4110-MV800	Germany medium-voltage power grid (800 V)	-	Supported	Supported
63	Panama-MV800	Panama medium-voltage power grid (800 V)	-	-	Supported
64	Macedonia-MV800	North Macedonia medium-voltage power grid (800 V)	-	-	Supported
65	SINGAPORE-MV800	Singapore medium-voltage power grid	-	-	Supported
66	Cambodia-MV800	Cambodia medium-voltage power grid	-	-	Supported

No.	Grid Code	Description	SUN2000-175KTL-H0	SUN2000-185KTL-INH0	SUN2000-185KTL-H1
67	GREG060-MV800	Colombia medium-voltage power grid	-	-	Supported
68	PERU-MV800	Peru medium-voltage power grid	-	-	Supported

 **NOTE**

The grid codes are subject to change. The listed codes are for your reference only.

---

# E Acronyms and Abbreviations

---

## C

**CEC** California Energy Commission

**CPV** Concentrated Photovoltaics technology

## L

**LED** light emitting diode

## M

**MBUS** monitoring bus

**MPP** maximum power point

**MPPT** maximum power point tracking

## P

**PID** potential induced degradation

**PV** photovoltaic

**R**

**RCMU** residual current  
monitoring unit

**W**

**WEEE** waste electrical and  
electronic equipment